

CONSOLE CASE

D-2012AS

Thank you for purchasing TOA's Console Case.

Please carefully follow the instructions in this manual to ensure long, trouble-free use of your equipment.

1. SAFETY PRECAUTIONS

Be sure to follow all the precautionary instructions in this section, which contain important cautions regarding safety.

After reading, keep this manual handy for future reference.



CAUTION

Indicates a potentially hazardous situation which, if mishandled, could result in moderate or minor personal injury, and/or property damage.

- Avoid touching the decorative panel's sharp metal edge to prevent injury.

2. GENERAL DESCRIPTION

The D-2012AS Console Case is a desk mount kit for the D-2012C Remote Console Unit, which includes an armrest, side and decorative panels.

3. COMPONENT PARTS

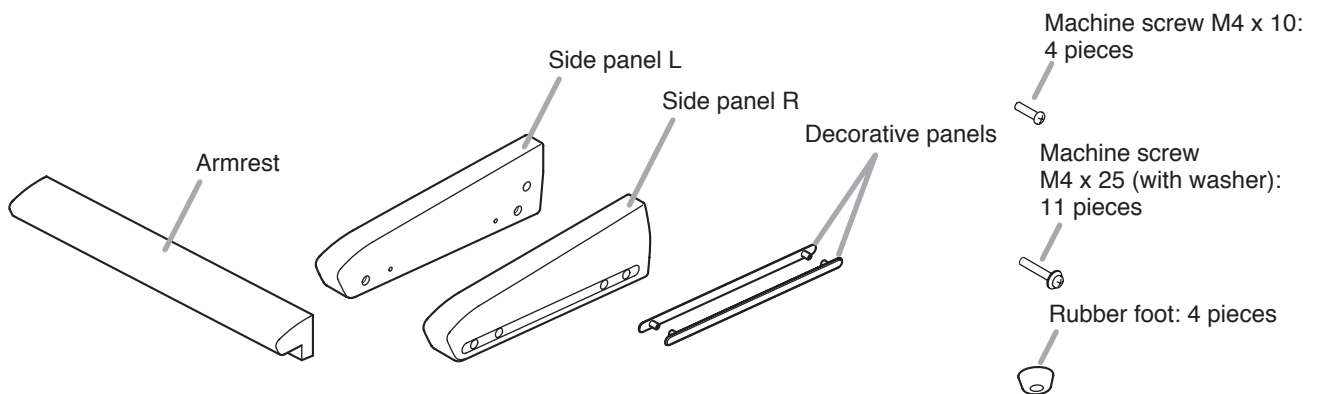

4. HOW TO ASSEMBLE

Step 1. Remove 3 screws on each side of the D-2012C to detach the rack mounting brackets. The removed screws are not used.

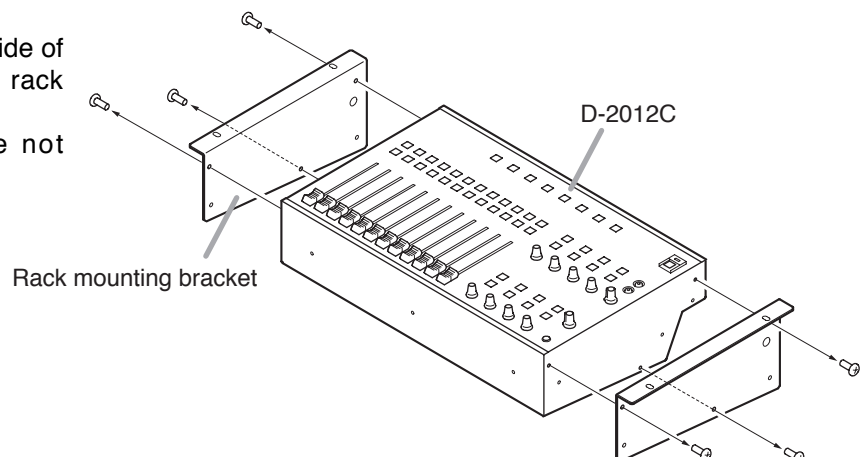

Step 2. Attach the 4 rubber feet to the bottom surface of the D-2012C using the 4 supplied screws.
Be sure to attach the rubber feet, as the air vents are provided at the bottom surface.

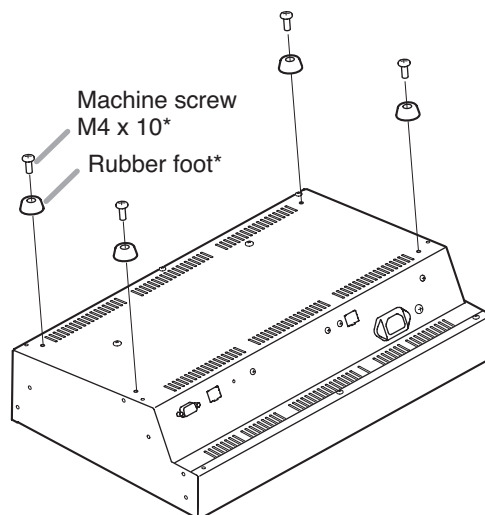

Step 3. Attach the side panel L to the left side of the D-2012C and side panel R to its right side with 2 each screws.

Step 4. Fit each decorative panel into the holes on the side panels L and R, then secure them with 2 each screws from the side panels inside.

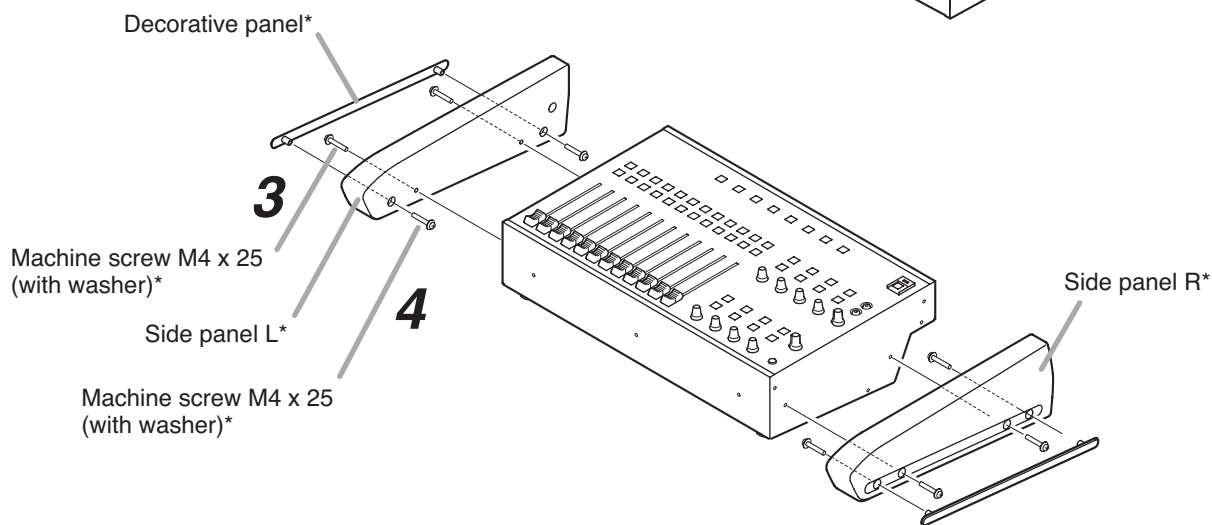

Step 5. Attach the armrest to the D-2012C's front panel with 3 screws.

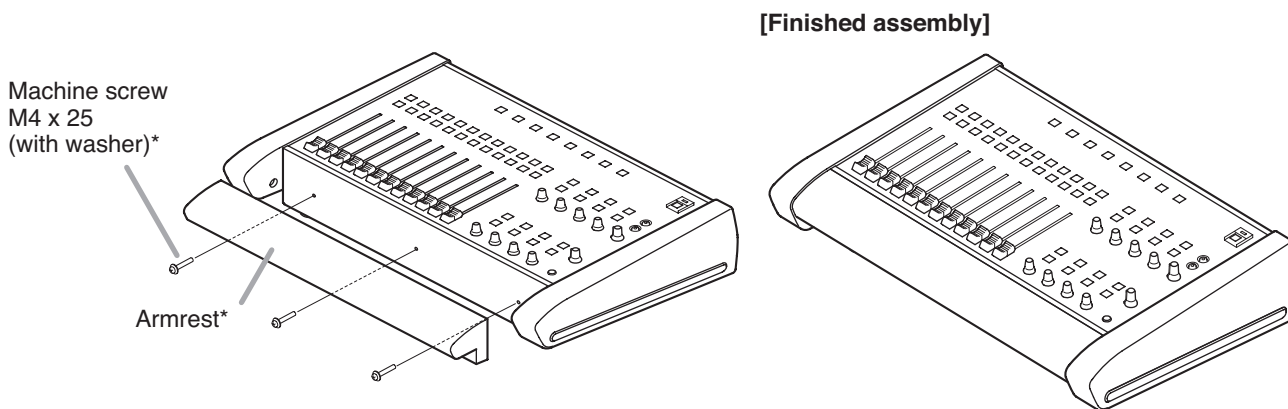

* Component parts of the D-2012AS.

5. SPECIFICATIONS

Finish	Side panels: MDF, paint, black, mat finish Armrest: MDF, leather upholstery, black, mat finish Decorative panels: Stainless steel, silver
Dimensions	505 (w) x 127.5 (h) x 333.4 (d) mm or 19.88" x 5.02" x 13.13" (assembled)
Weight	2.3 kg or 5.07 lb (this product only), 7.5 kg or 16.54 lb (assembled)

Note: The design and specifications are subject to change without notice for improvement.