



INSTALLATION MANUAL

VX-2000 series

PILOT TONE DETECTION MODULE VX-200SP-2

IMPEDANCE DETECTION MODULE VX-200SZ-2

Thank you for purchasing TOA's VX-2000 series plug-in modules.
Please carefully follow the instructions in this manual to ensure long, trouble-free use of your equipment.

TOA Corporation

TABLE OF CONTENTS

1. GENERAL DESCRIPTION	3
2. HANDLING PRECAUTIONS	3
3. MAXIMUM SYSTEM EXAMPLE	4
3.1. Block Diagram	4
3.2. Maximum System Configuration Table	5
4. NOMENCLATURE AND FUNCTIONS	6
4.1. Pilot Tone Detection Module VX-200SP-2	6
4.2. Impedance Detection Module VX-200SZ-2	7
5. SPEAKER LINE FAILURE DETECTION METHODS	9
5.1. Pilot Tone Detection Method	9
5.2. Impedance Detection Method	10
6. INSTALLATION	11
6.1. Changing the VX-200SZ-2's ATT CTRL Output to Photocoupler Type	11
6.2. Installing the VX-200SE in the VX-200SZ-2 and VX-200SP-2	12
6.3. Installing Modules (VX-200SZ-2, VX-200SP-2) in the VX-2000SF Frame	13
7. CONNECTIONS	14
7.1. VX-200SP-2 and VX-200SZ-2 Connection to Power Amplifier and Speakers	14
7.2. VX-200SP-2 Connection to External Attenuator	16
7.3. VX-200SZ-2 Connection to External Attenuator	16
8. LIST OF CONNECTION CABLES	17
9. CABLE CONNECTIONS TO RJ45 CONNECTORS	18
10. MONITORING LOG LIST	19
11. BLOCK DIAGRAM	20
11.1. Pilot Tone Detection Module VX-200SP-2	20
11.2. Impedance Detection Module VX-200SZ-2	21
12. SPECIFICATIONS	22
12.1. Pilot Tone Detection Module VX-200SP-2	22
12.2. Impedance Detection Module VX-200SZ-2	23

1. GENERAL DESCRIPTION

[VX-200SP-2]

The VX-200SP-2 is an audio signal output module of the VX-2000 system with speaker line pilot tone detection. This module is to be mounted in the VX-2000SF Surveillance Frame and detects speaker line short circuits, open circuits by monitoring the terminated resistance value of the End-of-line (EOL) unit, and ground fault. Connecting the supplied EOL unit to the end of the speaker line eliminates the necessity of using the speaker line for line monitoring. However, the shielded cable must be used for speaker line.

[VX-200SZ-2]

The VX-200SZ-2 is an audio signal output module of the VX-2000 system with speaker line impedance detection. This module is to be mounted in the VX-2000SF Surveillance Frame and detects speaker line short circuits, open circuits by comparing impedance readings, and ground fault. Since the module is equipped with 2 speaker outputs (A and B), broadcasts can be maintained even if one of the two outputs fails. Failures are indicated by the LEDs on the panel.

2. HANDLING PRECAUTIONS

- Do not install the unit in locations exposed to the direct sunlight or heaters, as the unit could be deformed or discoloured.
- Avoid installing or storing the unit in dusty or humid locations, as doing otherwise could cause the unit's failure.
- Keep the unit as far away as possible from a fluorescent lamp, digital equipment, PC or other equipment which generate high frequency noise.
- Because each unit is not "hot-pluggable," the system needs to be shut down when it is installed or removed. For turning the system power off, refer to the VX-2000 series Instruction manual.

3. MAXIMUM SYSTEM EXAMPLE

3.1. Block Diagram

The following block diagram shows the maximum sized system that can be assembled with the VX-2000 Series.

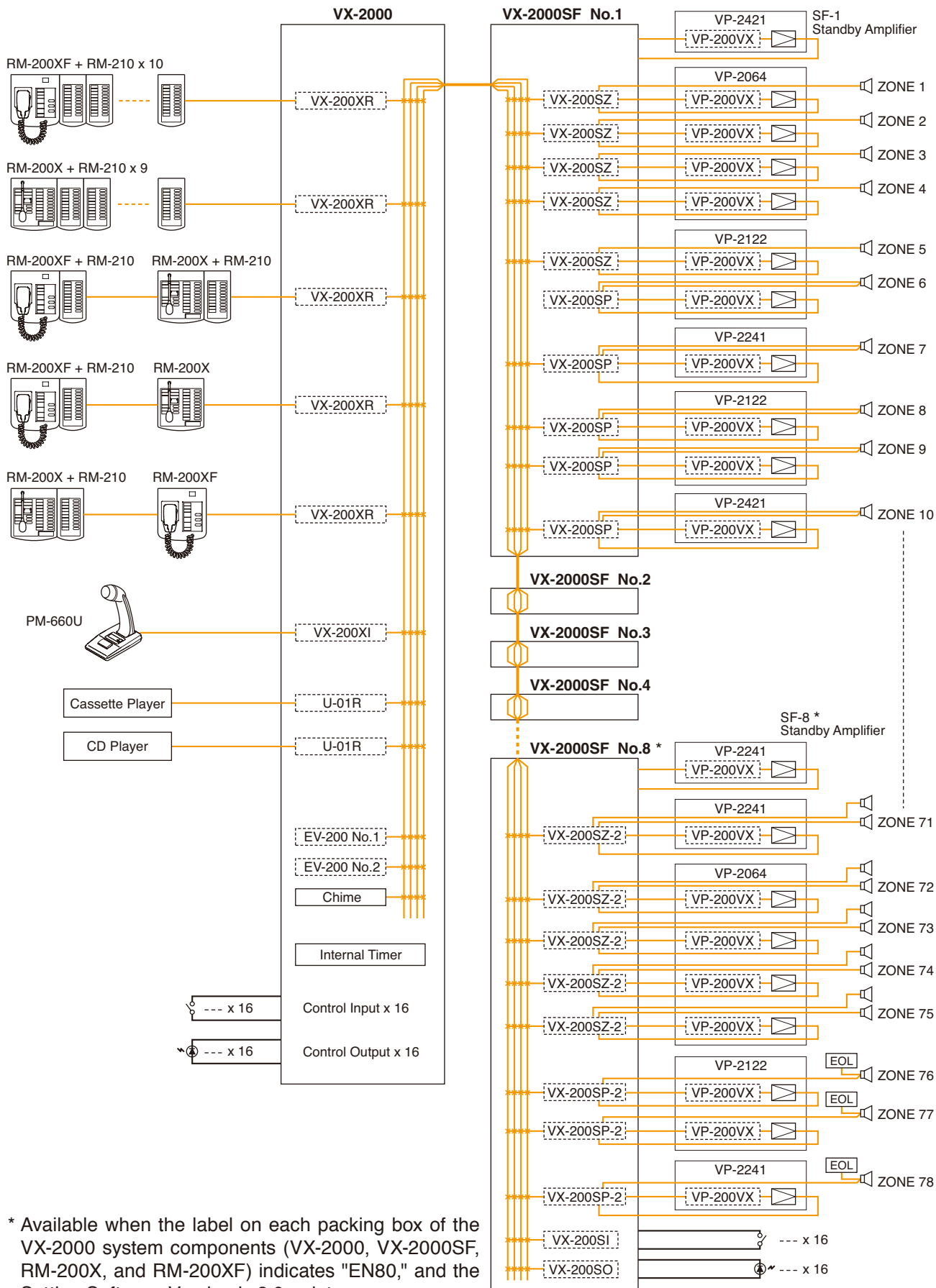

* Available when the label on each packing box of the VX-2000 system components (VX-2000, VX-2000SF, RM-200X, and RM-200XF) indicates "EN80," and the Setting Software Version is 3.0 or later.

3.2. Maximum System Configuration Table

Component	Maximum No. of Units			
Input Source Equipment				
RM-200XF	4 units	4 units in total of Emergency-set models	8 units in total of both models	18 units in total of all Input Source Equipment
RM-200X	4 units ("Emergency" type) 8 units ("General" type)			
Paging Microphone and Music Sources (Cassette, CD, etc.)	8 units			
EV-200	2 units			
Chime (internal)	1 unit			
RM-200XF's and RM-200X's Function Key Extension				
RM-210	10 units (115 function keys) per RM-200XF 9 units (115 function keys) per RM-200X	315 function keys per system		
VX-2000				
VX-2000	1 unit			
Input Module (to be installed in VX-2000)				
VX-200XR VX-200XI 900 module	8 units in total of all Input Modules Usable 900 modules: M-01F, M-01M, M-01P, M-01S, M-01T, M-03P, M-51F, M-51S, M-51T, M-61F, M-61S, M-61T, U-01F, U-01P, U-01R, U-01S, U-01T, U-03R, U-03S, U-61S, and U-61T			
VX-2000SF				
VX-2000SF	8 units*			
SF Module (to be installed in VX-2000SF)				
VX-200SP, VX-200SP-2	80 units	80 units in total of all SF Modules (10 units per VX-2000SF)		
VX-200SZ, VX-200SZ-2	80 units			
VX-200SI	7 units			
VX-200SO	7 units			
Optional Equaliser Card (to be installed VX-200SP, VX-200SP-2, VX-200SZ and VX-200SZ-2)				
VX-200SE	80 units			
Control Input				
VX-2000	16 inputs (as standard equipment)	128 inputs in total		
VX-200SI	112 inputs (7 units)			
Control Output				
VX-2000	16 outputs (as standard equipment)	128 outputs in total		
VX-200SO	112 outputs (7 units)			
Power Amplifier				
Note: The number and type of power amplifiers should be determined depending on the required speaker output for each zone.				
VP-2064 (4 ch) VP-2122 (2 ch) VP-2241 (1 ch) VP-2421 (1 ch)	80 channels* (80 zones)*			
Standby Amplifier	8 channels* (1 channel per VX-2000SF)			
Power Amplifier Input Module				
VP-200VX	88 units* in total of modules installed in Power and Standby Amplifiers			
Power Supply				
Note: Necessary power capacity should be calculated based on total system specifications.				
VX-2000DS	16 units*	2 units per VX-2000SF		
VX-200PS	48 units*	3 units per VX-2000DS		
Battery	32 or 64 units*	2 or 4 units per VX-2000DS		

* Available when the label on each packing box of the VX-2000 system components (VX-2000, VX-2000SF, RM-200X, and RM-200XF) indicates "EN80," and the Setting Software Version is 3.0 or later.

4. NOMENCLATURE AND FUNCTIONS

4.1. Pilot Tone Detection Module VX-200SP-2

Install this module in the VX-2000SF Surveillance Frame to detect speaker line short circuits, open circuits by monitoring the terminated resistance value of the EOL unit, and ground fault.

The pilot tone can be detected by using the supplied EOL unit in combination.

Please equate this module as the VX-200SP when setting it on the PC software.

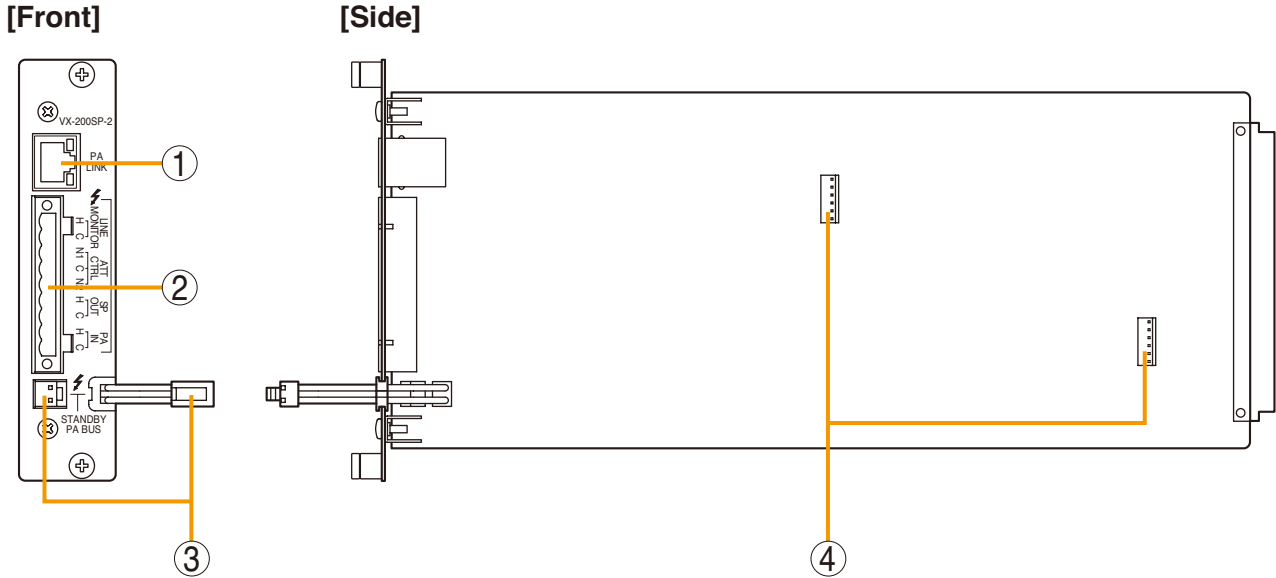

End-of-line (EOL) unit

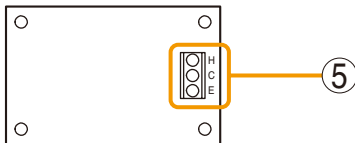

1. Power amplifier link connector [PA LINK]

This RJ45 connector connects to the PA LINK connector of the VP-200VX Power Amplifier Input module or the VP-3000 series Power Amplifier. Both LEDs on this connector are not used.

2. VX-200SP plug-in screw connector

Signal lines to be connected are shown below:

- **Line monitor input [LINE MONITOR]**
Monitors connected speaker lines.
Connect by wiring from the SP OUT.
- **External attenuator control [ATT CTRL]**
Permits connection of a 3- or 4-wire system attenuator.
For the attenuator connection, refer to [p. 16](#).
- **Speaker output [SP OUT]**
Connects to the speaker.
- **Power amplifier input [PA IN]**
Connects to the power amplifier's speaker output terminal.

3. Standby amplifier bus connector [STANDBY PA BUS]

Connects to all outputs of a single VX-2000SF unit to be switched over to the standby amplifier when the power amplifier fails.

For details, refer to the VX-2000 series Instruction manual.

4. VX-200SE mounting connector

Used to mount the VX-200SE Equaliser Card.

5. Speaker line connection terminal

Connect the EOL unit to the end of the speaker line.

Be sure to connect the speaker's shield cable to the E terminal of EOL unit, and the other end of the cable to the equipment's functional ground of the VX-2000 system.

4.2. Impedance Detection Module VX-200SZ-2

Install this module in the VX-2000SF Surveillance Frame to detect speaker line short circuits, open circuits by comparing impedance readings, and ground fault.

Please equate this module with the VX-200SZ when setting it on the PC software.

Important Note

When combining this module with the VP-200VX BGM Input Module, then the signal level applied to the VP-200VX's external input should be low, i.e. about 10 dB below the rated level. The level can also be reduced by the volume adjustment.

[Front]

[Side]

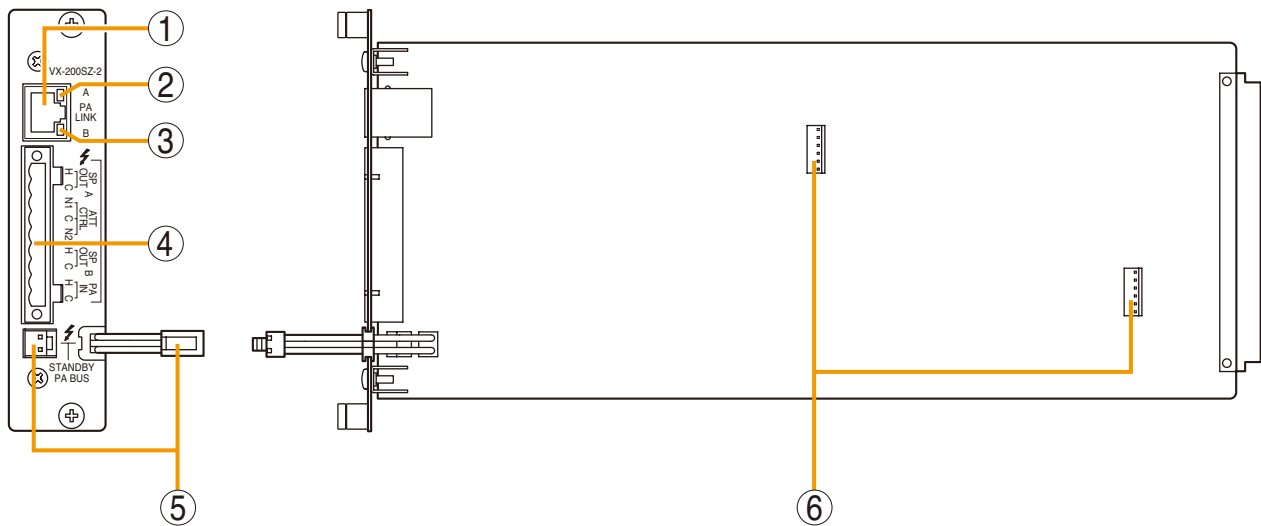

1. Power amplifier link connector [PA LINK]

This RJ45 connector connects to the PA LINK connector of the VP-200VX Power Amplifier Input module or the VP-3000 series Power Amplifier.

2. Speaker line A status indicator [A]

Shows the status of speaker line connected to the SP OUT A terminal.

For details, refer to [p. 8](#).

3. Speaker line B status indicator [B]

Shows the status of speaker line connected to the SP OUT B terminal.

For details, refer to [p. 8](#).

4. VX-200SZ plug-in screw connector

Signal lines to be connected are shown below:

- **External attenuator control [ATT CTRL]**
Permits connection of 4-wire system attenuators.
For the connection instructions, refer to [p. 15](#).
The attenuator bypass method can be changed from relay to photocoupler type. For the modification instructions, refer to [p. 11](#).
- **Speaker outputs A and B [SP OUT A, SP OUT B]**
Connect the speakers.
- **Power amplifier input [PA IN]**
Connects to the power amplifier's speaker output.

5. Standby amplifier bus connector [STANDBY PA BUS]

Connects to all outputs of a single VX-2000SF unit to be switched over to the standby amplifier when the power amplifier fails.

For details, refer to the VX-2000 series Instruction manual.

6. VX-200SE mounting connector

Used to mount the VX-200SE Equaliser card.

[Speaker line status vs. indicator status]

The Speaker line A or B status indicator shows the corresponding speaker line status "Normal," "Open," or "Short" by the indicator lighting conditions as follows.

• When the VX-200SZ-2 is used as factory-preset

This is the case where the initial impedance settings have not yet been performed or cannot be performed because of the speaker line failure.

(For the initial impedance settings, refer to the VX-2000 series Instruction manual.)

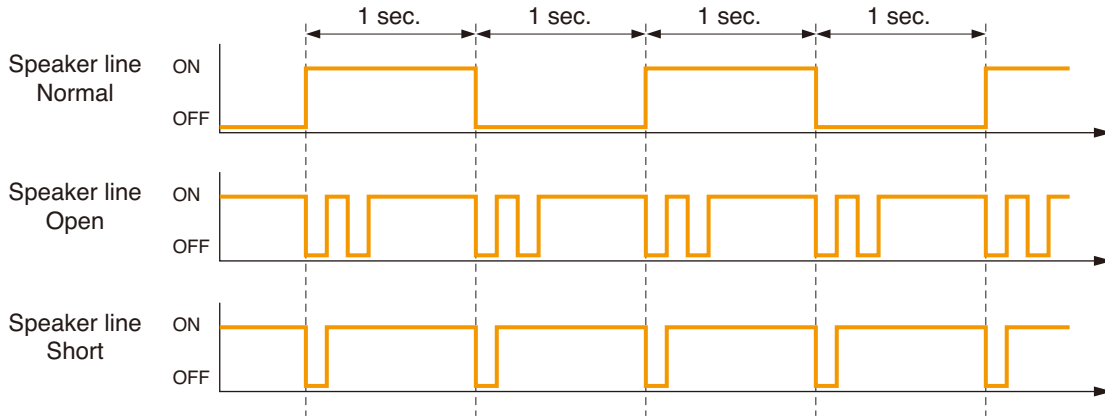

Note

When either indicator shows speaker line failure (open or short), another indicator showing normal status extinguishes.

• When the VX-200SZ-2 is in normal operating mode

This is the case where the initial impedance settings have been completed.

(For the initial impedance settings, refer to the VX-2000 series Instruction manual.)

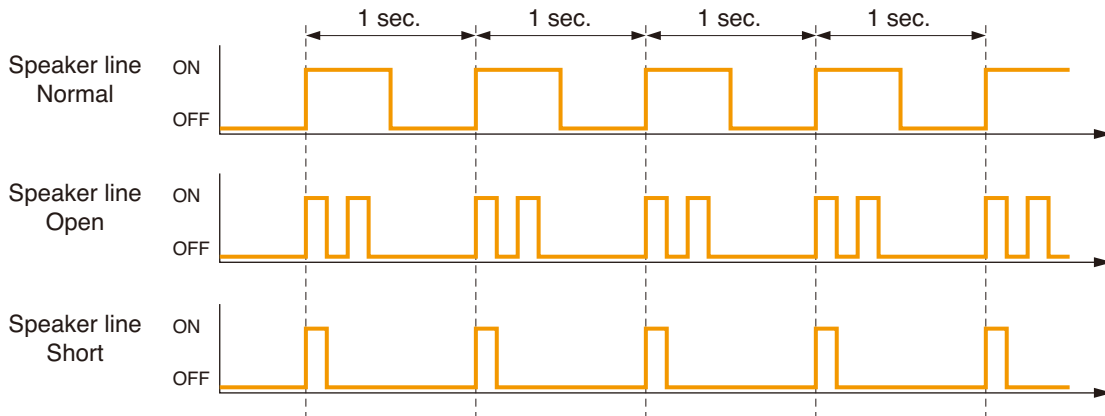

The table below shows the speaker line A and B status (indicators status) and its log data to be displayed on a PC.

Speaker line A (See the indicator status above.)	Speaker line B (See the indicator status above.)	Log displayed on a PC
Normal	Normal	NORMAL
Open	Normal	OPEN
Normal	Open	OPEN
Short	Normal	OPEN*
Normal	Short	OPEN*
Open	Open	OPEN
Short	Short	SHORT
Open	Short	OPEN*
Short	Open	OPEN*

* After the VX-200SZ-2 detects line "Short" on either the speaker line A or B, the shorted speaker line will be automatically disconnected, permitting the log data to be displayed as "Open" on a PC.

5. SPEAKER LINE FAILURE DETECTION METHODS

Note

The failure detection functions described here are designed to perform on a 100-volt line of speaker. For the methods using a 70- or 50-volt line, please consult your TOA dealer.

5.1. Pilot Tone Detection Method

The VX-200SP-2 Pilot Tone Detection module detects speaker line failures by using a pilot tone. A 20 kHz failure detection pilot signal is superimposed on the signal line. To detect speaker line failures, the VX-200SP-2 module is used with the supplied End-of-line (EOL) unit in combination. The module's Detector circuit controls the pilot tone detection by monitoring the terminated resistance value of the EOL unit, bringing the same result as brought in the way that the VX-200SP checks the signal return from the speaker line end.

[VX-200SP-2 Failure detection]

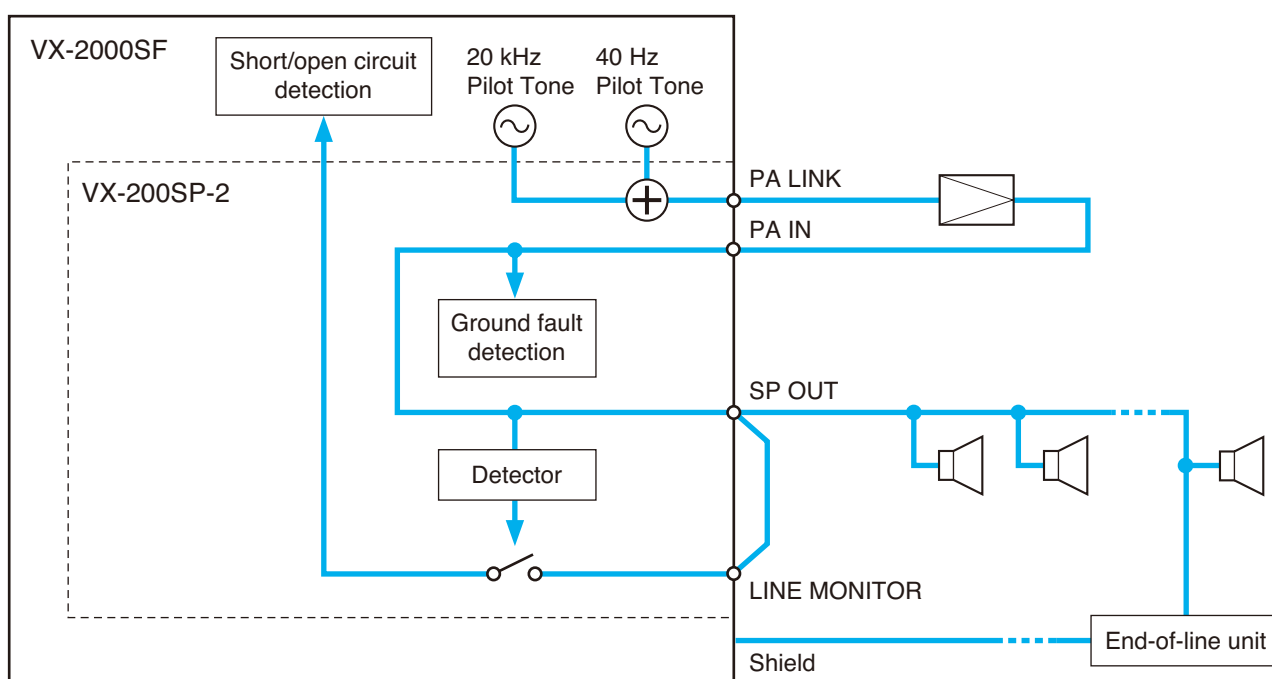

5.2. Impedance Detection Method

The VX-200SZ-2 Impedance Detection module compares impedances to detect speaker line failures. A 40Hz pilot signal for impedance detection is superimposed on the signal line. The VX-200SZ-2 checks the impedance before the [SP OUT] terminal, and compares it with the initially set impedance to detect speaker line failures. The VX-200SZ-2 module's initial impedance value must be set at the time of installation or during periodic service maintenance.

The VX-200SZ-2 can connect 2 speaker lines that work simultaneously during paging.

Both lines (or SP OUT A and B) cannot be programmed as individual call zones.

Once the line is shorted, it remains disconnected from the speaker output until resetting.

Once the line is opened, it will be automatically monitored every hour to see if the line is recovered.

Refer to the VX-2000 series Instruction manual.

[VX-200SZ-2 Failure detection]

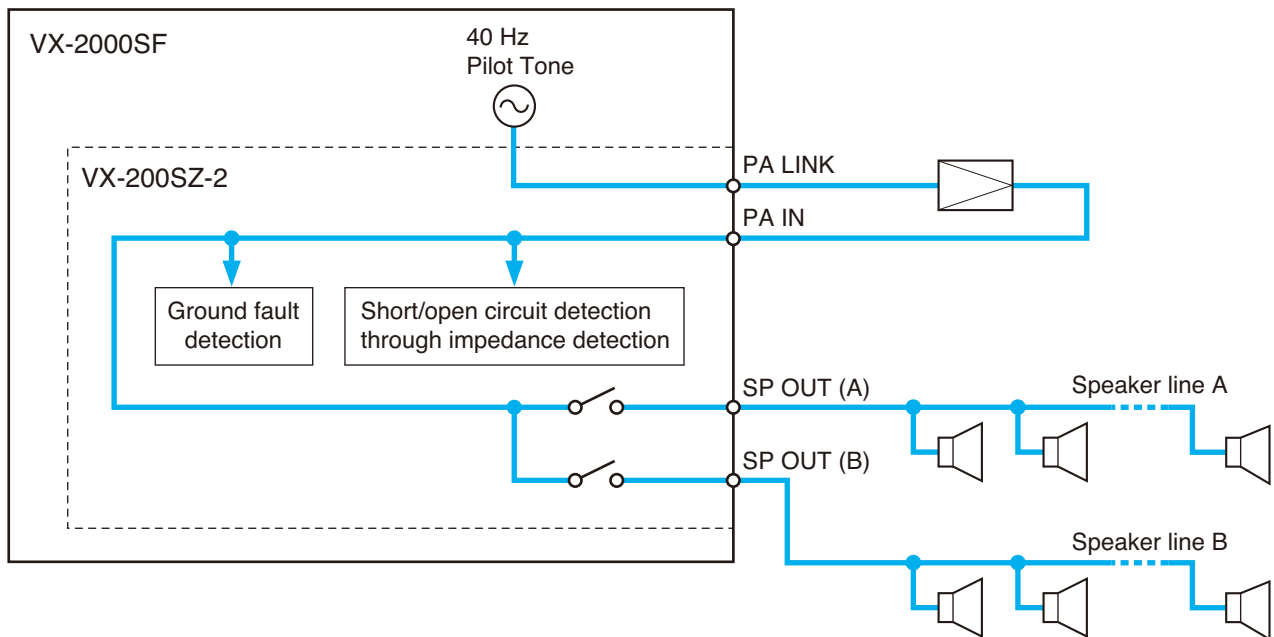

Notes

- Observe the following relationship between the amplifier's power output and connected speaker's input power: Amplifier wattage \geq Speaker wattage on the speaker line A + Speaker wattage on the speaker line B
- Make the speaker wattage on each of the speaker lines A and B almost the same (within 10%).

6. INSTALLATION

6.1. Changing the VX-200SZ-2's ATT CTRL Output to Photocoupler Type

The ATT CTRL output of the VX-200SZ-2 Impedance Detection Module can be converted from relay to photocoupler operation. The output is factory-preset for relay operation.

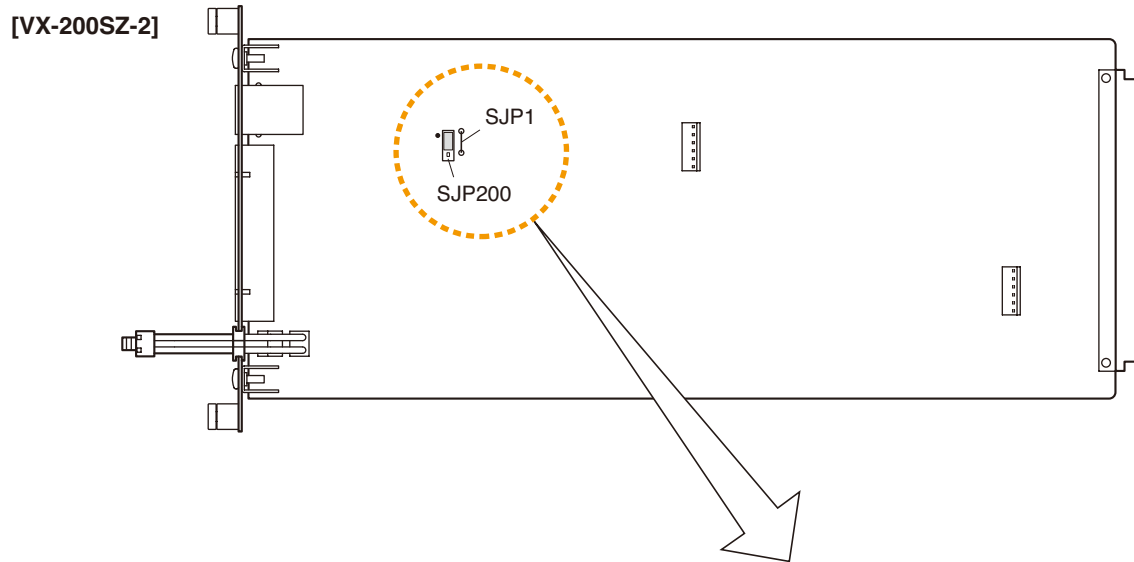

Step 1. Cut SJP1 with nippers or other cutters.

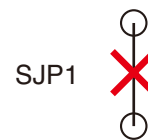

Step 2. Remove the short circuit socket (SJP200), then replace it to change its position.

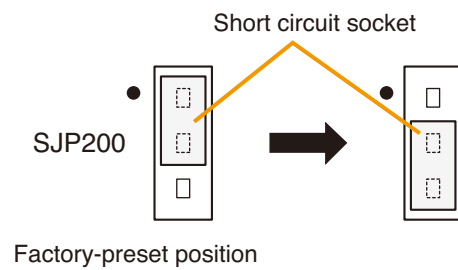

6.2. Installing the VX-200SE in the VX-200SZ-2 and VX-200SP-2

- A 9-band, single-channel equaliser function can be added by installing the VX-200SE Equaliser Card in the VX-200SZ-2 Impedance Detection Module or the VX-200SP-2 Pilot Tone Detection Module.
- In the PC software settings, "EQ" must be set to ON for the VX-200SZ-2 and the VX-200SP-2 in which the VX-200SE is installed. For details, refer to the VX-2000 series Instruction manual.
- Use the PC software to perform equaliser setting. For details, refer to the VX-2000 series Instruction manual.

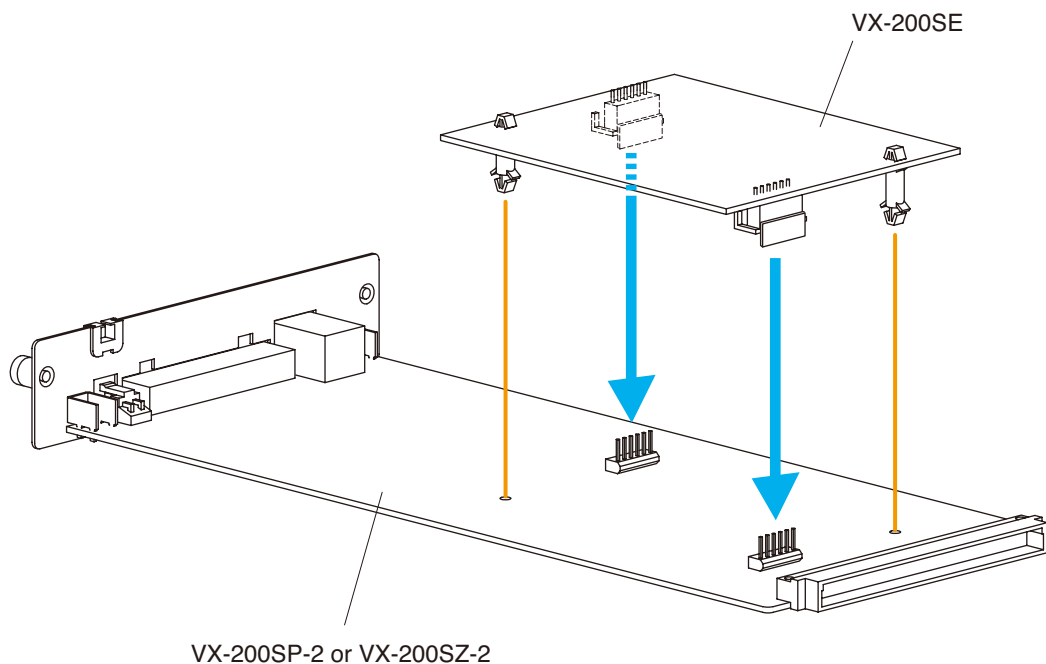

6.3. Installing Modules (VX-200SZ-2, VX-200SP-2) in the VX-2000SF Frame

Notes

- The slot number and module type to be installed must be identical to those designated by the PC software.
- Equate the VX-2000SZ-2 as VX-200SZ, and the VX-200SP-2 as VX-200SP when setting them on the PC software.
- Cover idle slots with the supplied blank panels to prevent dust from getting into the equipment.

Step 1. Align the module with the rails inside the VX-2000SF Frame, then push the module in to plug its connector strip securely into the VX-2000SF's internal connector.

Step 2. Tighten both the top and bottom screws.

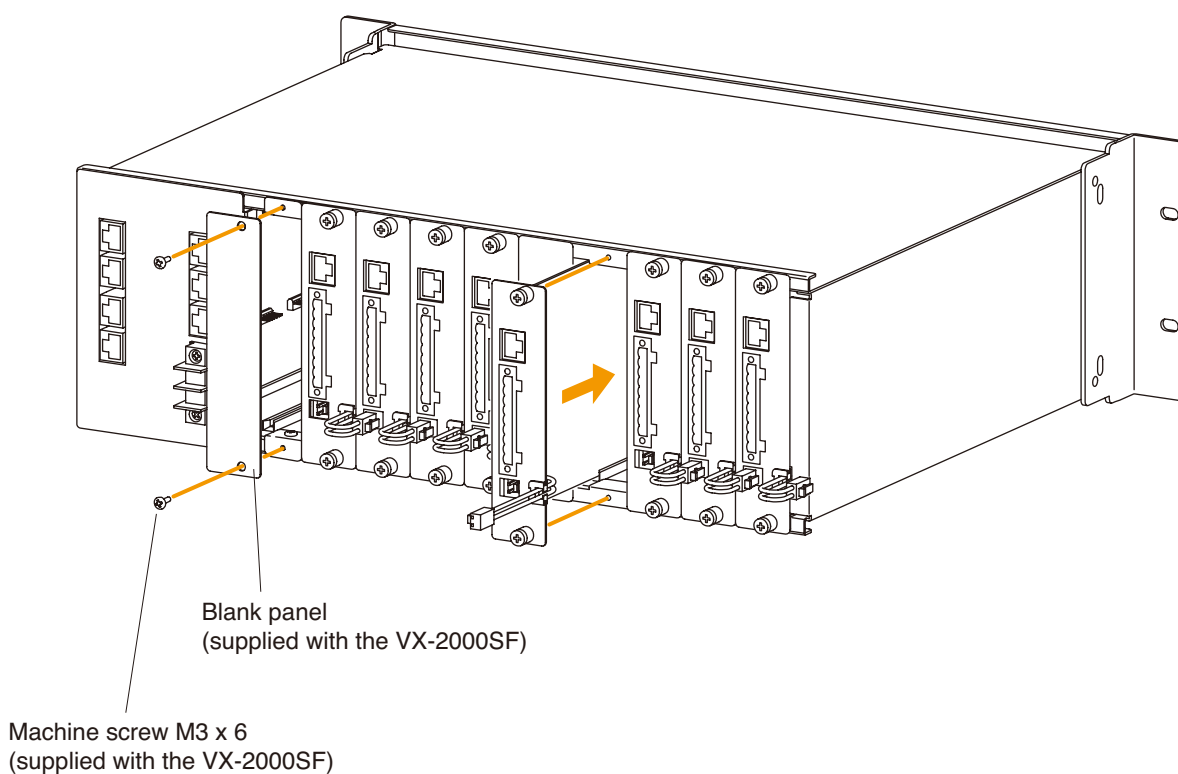

7. CONNECTIONS

7.1. VX-200SP-2 and VX-200SZ-2 Connection to Power Amplifier and Speakers

[When VP-2122 is used]

 --- RJ45 male connector

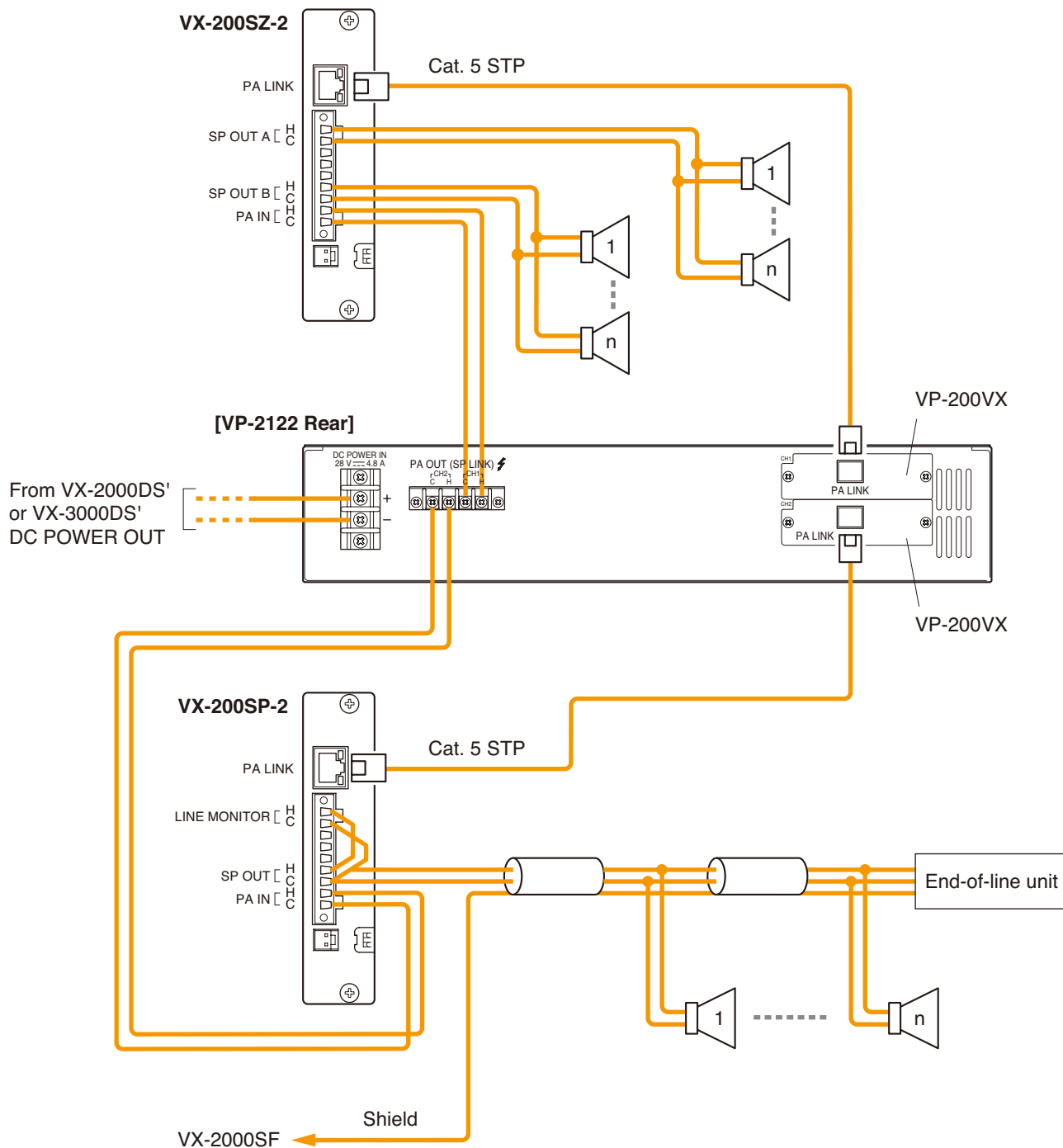

Note

After bundling all the speaker shield cables from the individual VX-200SP-2 modules into one cable at a terminal board, connect the cable to the VX-2000SF's chassis ground.

[When VP-3304 is used]

 --- RJ45 male connector

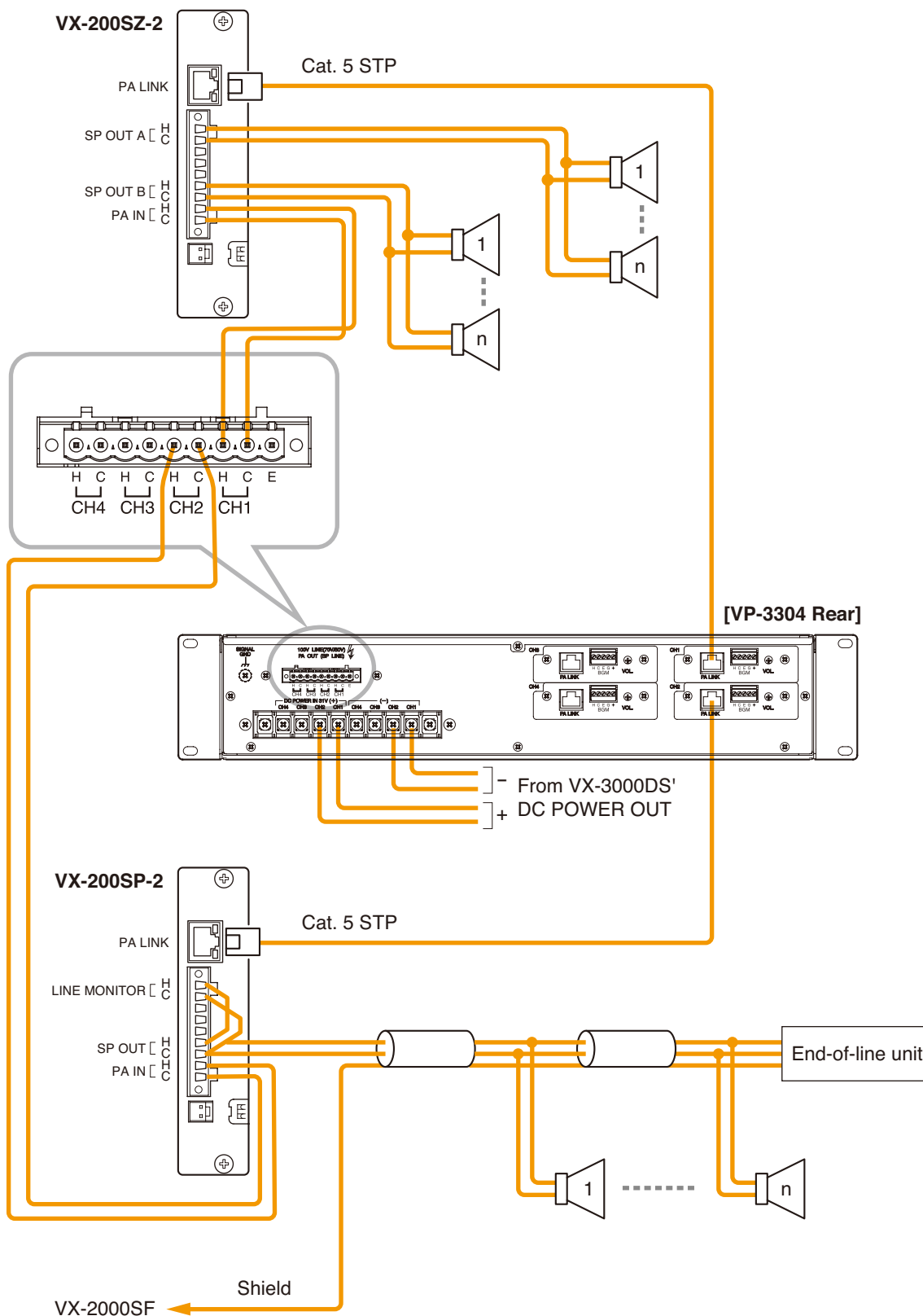

Note

After bundling all the speaker shield cables from the individual VX-200SP-2 modules into one cable at a terminal board, connect the cable to the VX-2000SF's chassis ground.

7.2. VX-200SP-2 Connection to External Attenuator

7.2.1. 3-wire system connection

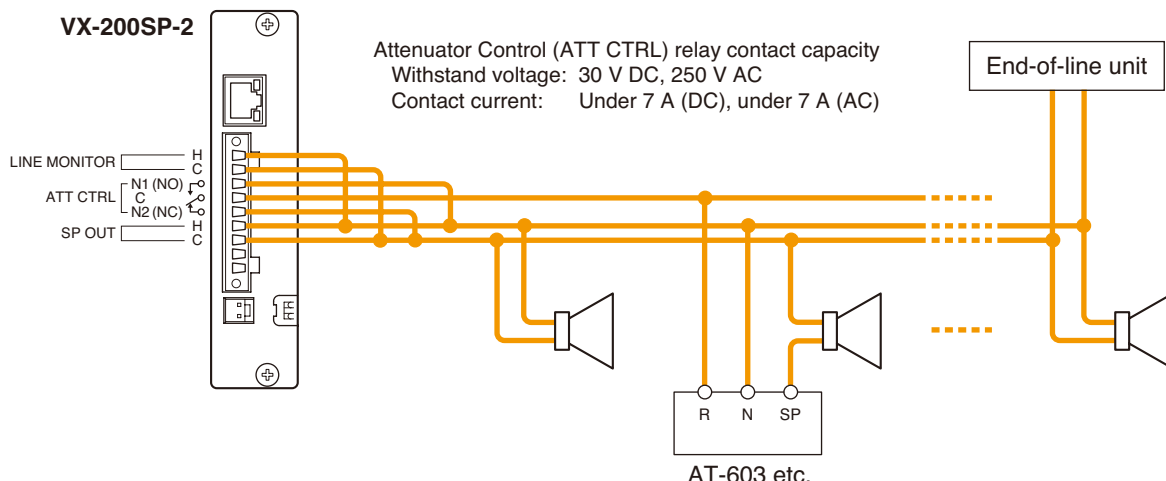

7.2.2. 4-wire system connection

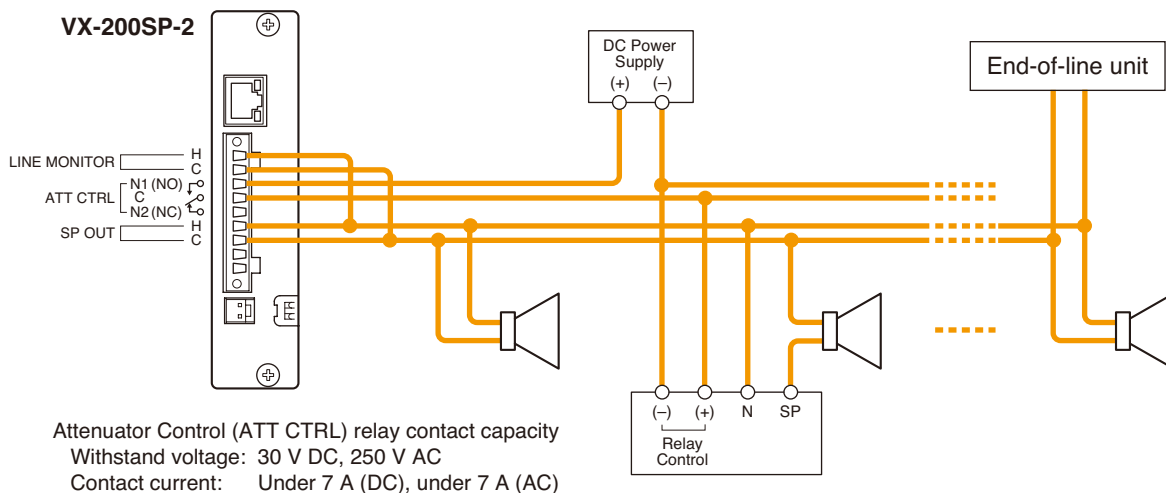

Note: This attenuator is assumed to be bypassed when the system power is turned on.

7.3. VX-200SZ-2 Connection to External Attenuator

Note: Only the external attenuators of 4-wire system can be used for the VX-200SZ-2.

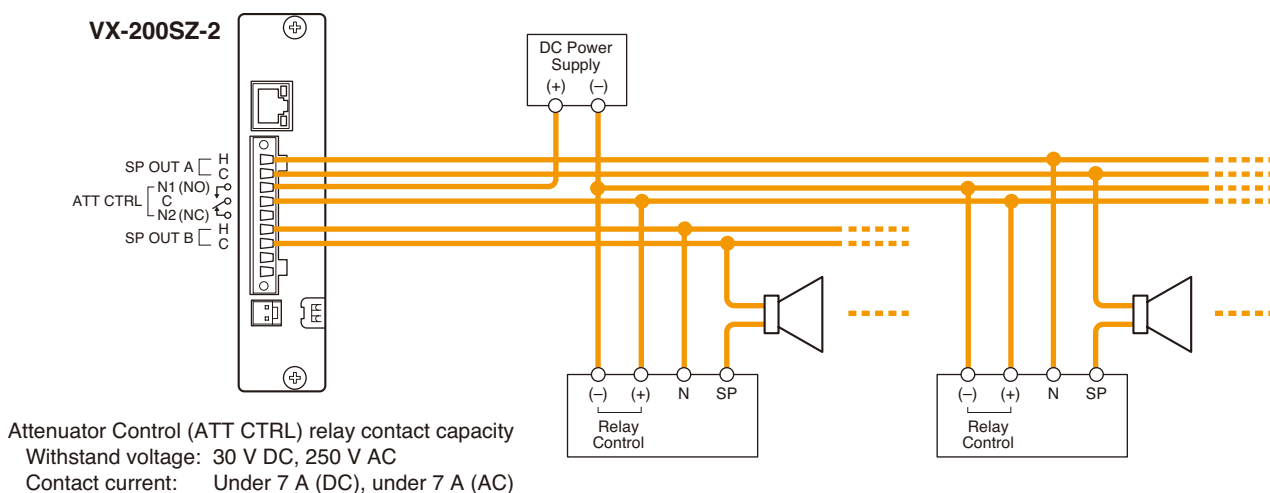

Note: This attenuator is assumed to be bypassed when the system power is turned on.

8. LIST OF CONNECTION CABLES

[VX-200SP-2]

Terminal to Connect		Cable Type			Equipment to be Connected to		
Terminal Name	Equipment Receptacle	Plug	Cable Type	Plug	Equipment	Terminal Name	Equipment Receptacle
PA LINK	RJ45 (female)	RJ45 (male)	Cat. 5 STP	RJ45 (male)	VP-200VX VP-3154/3304/3504	PA LINK	RJ45 (female)
LINE MONITOR	Plug-in screw connector	Unprocessed cable end	16 – 24AWG	Unprocessed cable end	VX-200SP-2	SP OUT	Plug-in screw connector
ATT CTRL	Plug-in screw connector	Unprocessed cable end	3-wire: 16 – 24AWG 4-wire: Twisted pair cable	Unprocessed cable end	External attenuator	—	—
SP OUT	Plug-in screw connector	Unprocessed cable end	Shielded pair cable 16 – 24AWG	Unprocessed cable end	Speaker	Speaker terminal	Push-in terminal block
PA IN	Plug-in screw connector	Unprocessed cable end	16 – 24AWG	Round or Y terminal	VP-2064/2122/ 2241/2421	PA OUT (SP LINE)	2P screw terminal
				Unprocessed cable end	VP-3154/3304/ 3504		Plug-in screw connector
STANDBY PA BUS	2P VH connector	Round or Y terminal	18AWG	Round or Y terminal	Standby amplifier VP-2064/2122/ 2241/2421	PA OUT (SP LINE)	2P screw terminal
				Unprocessed cable end	VP-3154/3304/ 3504		Plug-in screw connector
STANDBY PA BUS	2P VH connector	—	PCB Cable	—	VX-200SP VX-200SZ	STANDBY PA BUS	—

End-of-line unit

Terminal to Connect		Cable Type			Equipment to be Connected to		
Terminal Name	Equipment Receptacle	Plug	Cable Type	Plug	Equipment	Terminal Name	Equipment Receptacle
3P screw connector		Unprocessed cable end	Shielded pair cable 16 – 22AWG	Unprocessed cable end	Speaker	Speaker terminal	Push-in terminal block

[VX-200SZ-2]

Terminal to Connect		Cable Type			Equipment to be Connected to		
Terminal Name	Equipment Receptacle	Plug	Cable Type	Plug	Equipment	Terminal Name	Equipment Receptacle
PA LINK	RJ45 (female)	RJ45 (male)	Cat. 5 STP	RJ45 (male)	VP-200VX VP-3154/3304/3504	PA LINK	RJ45 (female)
ATT CTRL	Plug-in screw connector	Unprocessed cable end	4-wire: Twisted pair cable	Unprocessed cable end	External attenuator	—	—
SP OUT A	Plug-in screw connector	Unprocessed cable end	16 – 24AWG	Unprocessed cable end	Speaker	Speaker terminal	Push-in terminal block
SP OUT B	Plug-in screw connector	Unprocessed cable end	16 – 24AWG	Unprocessed cable end	Speaker	Speaker terminal	Push-in terminal block
PA IN	Plug-in screw connector	Unprocessed cable end	16 – 24AWG	Round or Y terminal	VP-2064/2122/ 2241/2421	PA OUT (SP LINE)	2P screw terminal
				Unprocessed cable end	VP-3154/3304/ 3504		Plug-in screw connector
STANDBY PA BUS	2P VH connector	Round or Y terminal	18AWG	Round or Y terminal	Standby amplifier VP-2064/2122/ 2241/2421	PA OUT (SP LINE)	2P screw terminal
				Unprocessed cable end	VP-3154/3304/ 3504		Plug-in screw connector
STANDBY PA BUS	2P VH connector	—	PCB Cable	—	VX-200SP VX-200SZ	STANDBY PA BUS	—

9. CABLE CONNECTIONS TO RJ45 CONNECTORS

Connect a RJ45 connector to both ends of the Cat. 5 STP cable and make the following connections:

[Source to Connect]		[Source to be Connected to]	
Component	Connector Name	Component	Connector Name
VX-2000	DATA LINK	VX-2000SF	DATA LINK
VX-2000	AUDIO LINK OUT	VX-2000SF	AUDIO LINK IN
VX-2000SF	AUDIO LINK OUT	Next VX-2000SF	AUDIO LINK IN
VX-2000SF	DATA LINK	Next VX-2000SF	DATA LINK
VX-2000SF	STANDBY PA LINK	VP-200VX/VP-3000 series	PA LINK
VX-2000SF	DS-SF LINK 1, 2	VX-2000DS/3000DS	DS-SF LINK/DS- LINK IN
VX-200SP	PA LINK	VP-200VX/VP-3000 series	PA LINK
VX-200SZ	PA LINK	VP-200VX/VP-3000 series	PA LINK
VX-200SP-2	PA LINK	VP-200VX/VP-3000 series	PA LINK
VX-200SZ-2	PA LINK	VP-200VX/VP-3000 series	PA LINK

[RJ45 connector pin assignment]

RJ45 Pin No.	Colour*	Pair
①	Orange / white	[Diagram: Pair 1]
②	Orange	
③	Green / white	[Diagram: Pair 2]
④	Blue	
⑤	Blue / white	[Diagram: Pair 3]
⑥	Green	
⑦	Brown / white	[Diagram: Pair 4]
⑧	Brown	
Shield	Shield	

* Differs from cable makers. In wiring, refer to the cable specifications for colour.

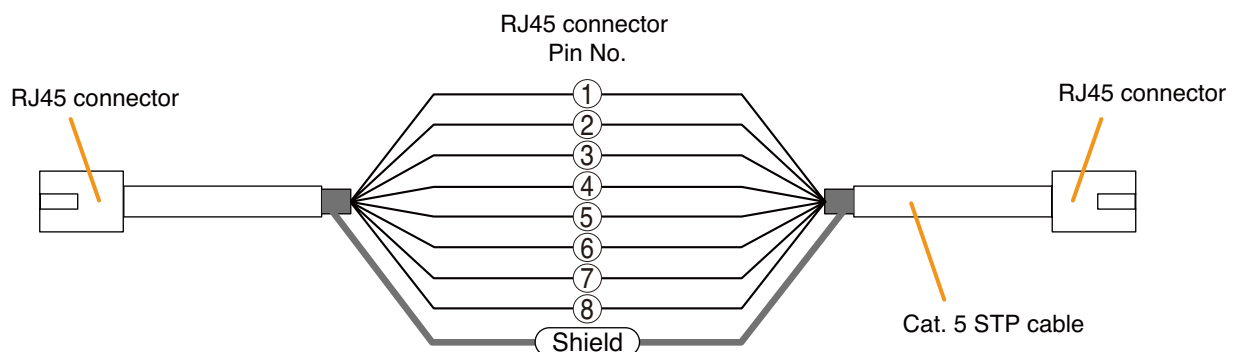

10. MONITORING LOG LIST

Possible causes of detected failures can be confirmed in the View Log window. For reading out the log file, refer to the VX-2000 series Instruction manual.

Table below lists failure logs, possible causes, and their solutions.

[VX-200SP-2]

Log		Possible Cause	Solution
Detail code	Additional Information		
SP Monitor	SP* Open Circuit Occurrence	Speaker line disconnected End-of-line unit failed Speaker line shorted (far end)	Check for the speaker, its connection, cable, and End-of-line unit.
	SP* Short Circuit Occurrence	Speaker line shorted	
	SP* Ground Fault Occurrence	Speaker line grounded	

* A speaker Zone number is displayed here.

[VX-200SZ-2]

Log		Possible Cause	Solution
Detail code	Additional Information		
SP Monitor	SP* Open Circuit Occurrence	Speaker line A disconnected Speaker line B disconnected Speaker line A shorted Speaker line B shorted	Check for the speaker, its connection, and cable.
	SP* Short Circuit Occurrence	Speaker line A and B shorted	
	SP* Ground Fault Occurrence	Speaker line grounded	

* A speaker Zone number is displayed here.

Note

Regarding the "Open Circuit Occurrence" information, identify the speaker line failure by checking the speaker line A and B status indicators on the module's front panel. (Refer to [p. 8.](#))

11. BLOCK DIAGRAM

11.1. Pilot Tone Detection Module VX-200SP-2

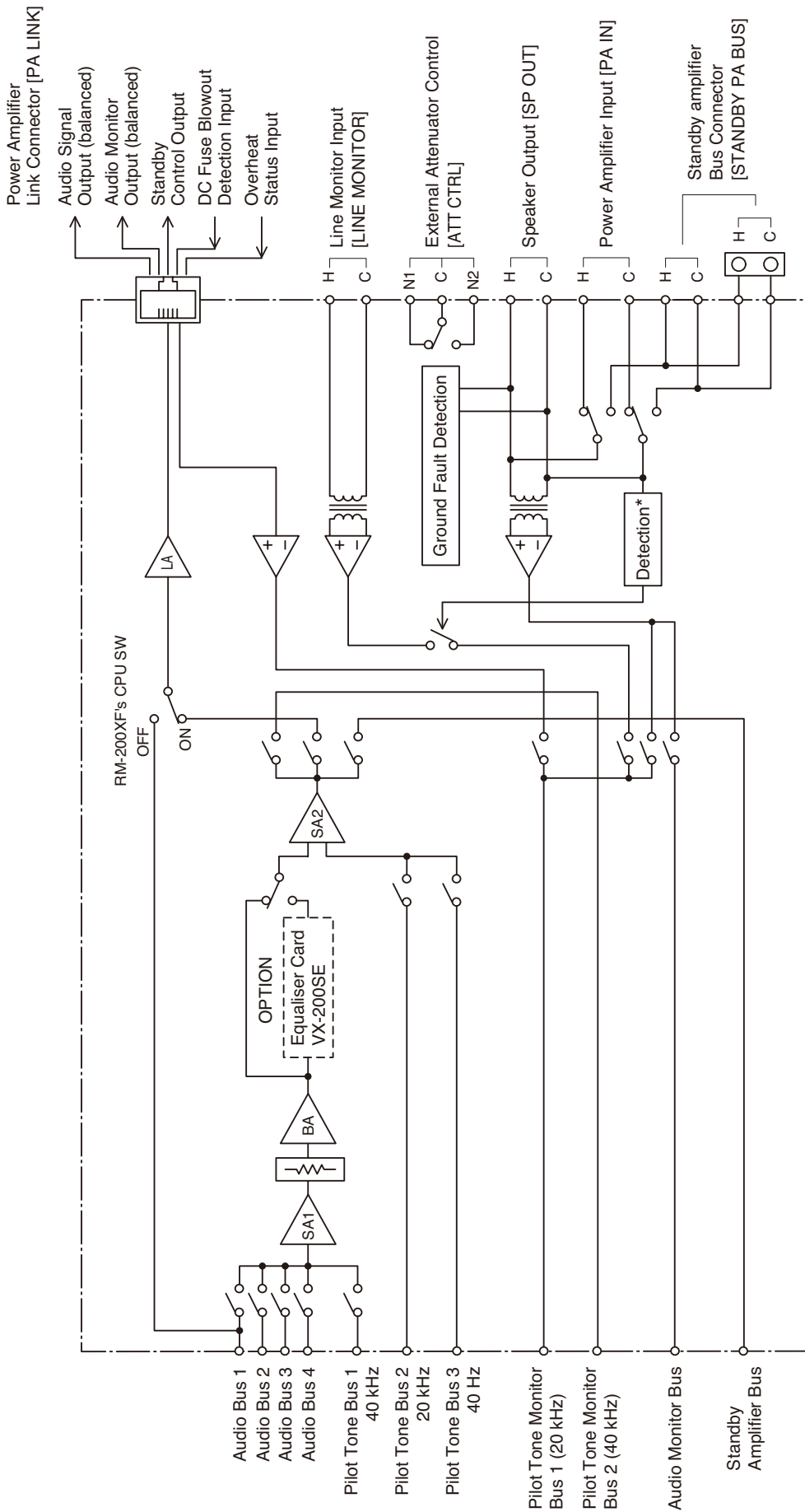

* Controls the switch pointed by an arrow with the voltage difference between the speaker line and the equipment chassis.

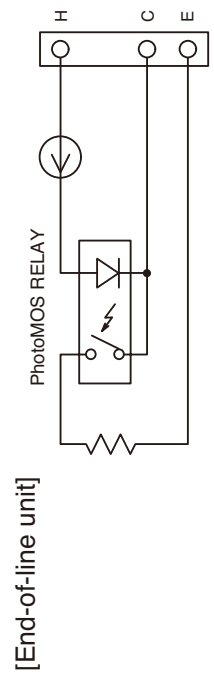

[End-of-line unit]

11.2. Impedance Detection Module VX-200SZ-2

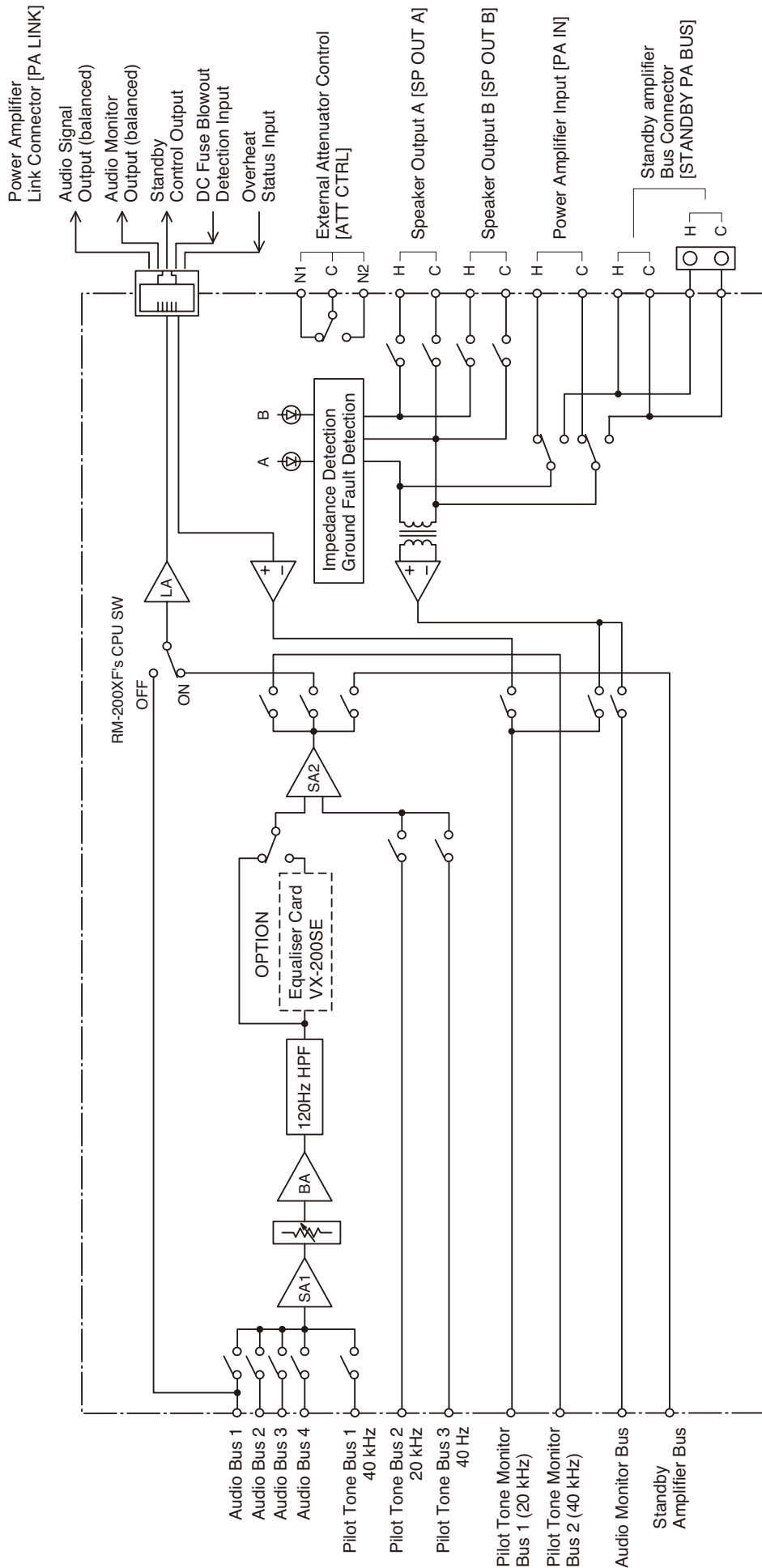

12. SPECIFICATIONS

12.1. Pilot Tone Detection Module VX-200SP-2

Power Source	Supplied from VX-2000SF
Current Consumption	Under 100 mA
Power Amplifier Link	RJ45 female connector for connecting the VP-2000 series or VP-3000 series Power Amplifier Twisted-pair straight cable (TIA/EIA-568A standard)
Line Monitor	Plug-in screw connector Applicable cable diameter: AWG 24 – AWG 16
External Attenuator Control output	Plug-in screw connector, relay, no-voltage make contact output, transfer type, withstand voltage: 30 V DC, 250 V AC, contact current: Under 7 A (DC), under 7 A (AC) Applicable cable diameter: AWG 24 – AWG 16
Speaker Output	Plug-in screw connector Applicable cable diameter: AWG 24 – AWG 16
Power Amplifier Input	Plug-in screw connector for connecting the VP-2000 series or VP-3000 series Power Amplifier Applicable cable diameter: AWG 24 – AWG 16
Fault Detection System	Short circuit, open circuit (pilot tone detection method), ground fault
Finish	Panel: Surface-treated steel plate
Dimensions	30.5 (w) x 132.6 (h) x 290.3 (d) mm
Weight	235 g
Applicable Model	VX-2000SF

Note: The design and specifications are subject to change without notice for improvement.

• Accessories

Plug-in screw terminal	1
End-of-line unit	1

• Optional product

Equaliser card: VX-200SE

[End-of-line unit (accessory)]

Power Source	Supplied from VX-200SP-2 (Generated by 40 Hz sine wave)
Speaker Line Input	Screw connector, Applicable cable diameter: AWG 24 – AWG 16
Operation Mode	Normal: Terminated by 470 kΩ between the speaker line and the shield Open: Opened between the speaker line and the shield
Dimensions	70 x 45 mm
Weight	22 g

12.2. Impedance Detection Module VX-200SZ-2

Power Source	Supplied from VX-2000SF
Current Consumption	Under 170 mA
Power Amplifier Link	RJ45 female connector for connecting the VP-2000 series or VP-3000 series Power Amplifier. Twisted-pair straight cable (TIA/EIA-568A standard)
External Attenuator Control Output	Plug-in screw connector, relay, no-voltage make contact output, transfer type, withstand voltage: 30 V DC, 250 V AC, contact current: Under 7 A (DC), under 7 A (AC) Applicable cable diameter: AWG 24 – AWG 16
Speaker Output	2 outputs (A, B), plug-in screw connector Applicable cable diameter: AWG 24 – AWG 16
Power Amplifier Input	Plug-in screw connector for connecting the VP-2000 series or VP-3000 series Power Amplifier Applicable cable diameter: AWG 24 – AWG 16
Fault Detection System	Short circuit, open circuit (impedance detection method), ground fault
Finish	Panel: Surface-treated steel plate
Dimensions	30.5 (w) x 132.6 (h) x 290.3 (d) mm
Weight	335 g
Applicable Model	VX-2000SF

Note: The design and specifications are subject to change without notice for improvement.

• Accessory

Plug-in screw terminal 1

• Optional product

Equaliser card: VX-200SE

