

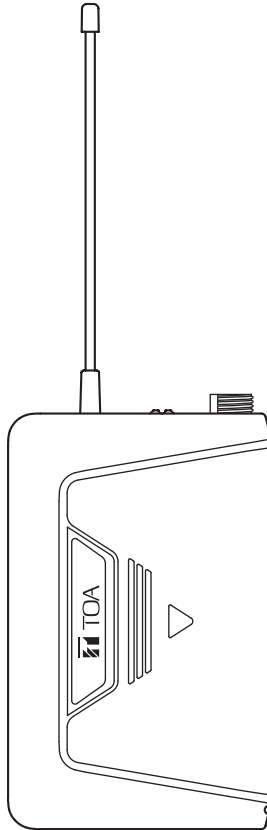

INSTRUCTION MANUAL

DIGITAL WIRELESS TRANSMITTER WM-D5300



Thank you for purchasing TOA's Digital Wireless Transmitter.
Please carefully follow the instructions in this manual to ensure long, trouble-free use of your equipment.

TABLE OF CONTENTS

1. SAFETY PRECAUTIONS	3
2. GENERAL DESCRIPTION	4
3. FEATURES	4
4. HANDLING PRECAUTIONS	4
5. NOMENCLATURE AND FUNCTIONS	5
6. PREPARING BATTERIES	7
6.1. Battery Insertion	7
6.2. Guide to Battery Operating Times	7
6.3. When Operating on Rechargeable Battery	8
7. OPERATION	9
7.1. Preparing Microphone	9
7.2. Using Transmitter	10
8. FUNCTION SETTINGS	10
8.1. Setting the Bank and Channel Numbers	10
8.2. Performing Encryption Settings	11
8.3. Performing Code Settings (When Encryption Function Is OFF)	13
8.4. Performing Transmission Output Changeover Switch Settings	14
9. CONVENIENT FUNCTIONS (MICROPHONE SENSITIVITY SELECTOR SWITCH SETTINGS)	15
10. SPECIFICATIONS	16
Accessories	16
Optional products	16

1. SAFETY PRECAUTIONS

- Before use, be sure to carefully read all the instructions in this section for correct and safe operation.
- Be sure to follow all the precautionary instructions in this section, which contain important warnings and/or cautions regarding safety.
- After reading, keep this manual handy for future reference.



WARNING

Indicates a potentially hazardous situation which, if mishandled, could result in death or serious personal injury.

When the Unit is in Use

- Be sure to use a dedicated battery charger when recharging a battery. Using other battery charger may cause the battery to leak or explode, resulting in a fire, personal injury, property damage, and/or pollution.
- To prevent the electromagnetic wave from badly influencing medical equipment, make sure to switch off the unit's power when placing it in close proximity to the medical equipment.



CAUTION

Indicates a potentially hazardous situation which, if mishandled, could result in moderate or minor personal injury, and/or property damage.

When the Unit is in Use

- When the unit is not in use for 2 weeks or more, be sure to take the batteries out of the unit because battery leakage may cause a fire, personal injury, or contamination of environment.
- Make sure to observe the following handling precautions so that a fire or personal injury does not result from leakage or explosion of the battery.
 - Do not short, disassemble, heat nor put the battery into a fire.

- Avoid using both new and old batteries together.
- Never charge batteries of the type which are not rechargeable.
- Do not solder a battery directly.
- Be sure to use the specified type of batteries.
- Note correct polarity (positive and negative orientation) when inserting a battery in the unit.
- Avoid locations exposed to the direct sunlight, high temperature and high humidity when storing batteries.

Do not place the dry cell battery into charger. Placing non-rechargeable batteries in the charger may cause the battery to crack resulting in a fire and/or harm to the body. When recharging, please only use the BC-2000 Battery charger and WB-2000 Battery. Do not use other battery types.

When the battery becomes inflated or leaks, discontinue use and replace with new one immediately.

If there's any burning and/or peculiar smell while charging the battery, please switch off the power immediately.

CAUTION TO USER:

Changes or modifications not expressly approved by the party responsible for compliance could void the user's authority to operate the equipment.

2. GENERAL DESCRIPTION

The WM-D5300 is a digital wireless transmitter to be used with the optional microphones, exclusively for speech applications.

The transmitter is specially designed to be used in conjunction with TOA's WT-D5800 digital wireless receiver.

3. FEATURES

- Employs the PLL-synthesizer system.
- TOA's unique digital audio processing technology ensures high quality sound.
- Digital transmission is highly resistant to radio interference and noise, enabling clearer, more stable communication.
- When used for important conferences or in other high-security venues, TOA's unique encryption software combines with digital transmission technology to prevent leakage of or eavesdropping on sensitive information.
- Switchable microphone sensitivity allows the unit to be used in a wide range of applications.
- Power can be supplied by either the dedicated rechargeable (NiH₂ = nickel-hydrogen) battery or an AA alkaline battery. When replacing the rechargeable battery, use the optional TOA WB-2000-2 (package of 2).

4. HANDLING PRECAUTIONS

- Do not expose the unit to rain or an environment where it may be splashed by water or other liquids, as doing so may result in unit failure.
- Never open nor remove the unit case to modify the unit. Refer all servicing to your nearest TOA dealer.
- Take care not to drop the unit onto the floor nor bump it against a hard object as the unit could fail.
- Do not place the unit in locations of high temperature (ex. in an ill-ventilated car in summer) or high humidity as the unit could fail.
- Do not use the unit in locations where it is exposed to seawater.
- To clean, use a dry cloth. When the unit gets very dirty, wipe lightly with a cloth dampened in a dilute neutral cleanser, then wipe with a dry cloth. Never use benzine, thinner, or chemically-treated cleaning towel.
- Avoid using a mobile telephone near the unit in use. Noise could be picked up.
- When using two or more units, keep them at least 50 cm away from each other to avoid malfunctions or noise.
- Keep the unit at least 3 m away from the receiving antenna. Using the unit in close proximity to the antenna could result in malfunctions or noise.

5. NOMENCLATURE AND FUNCTIONS

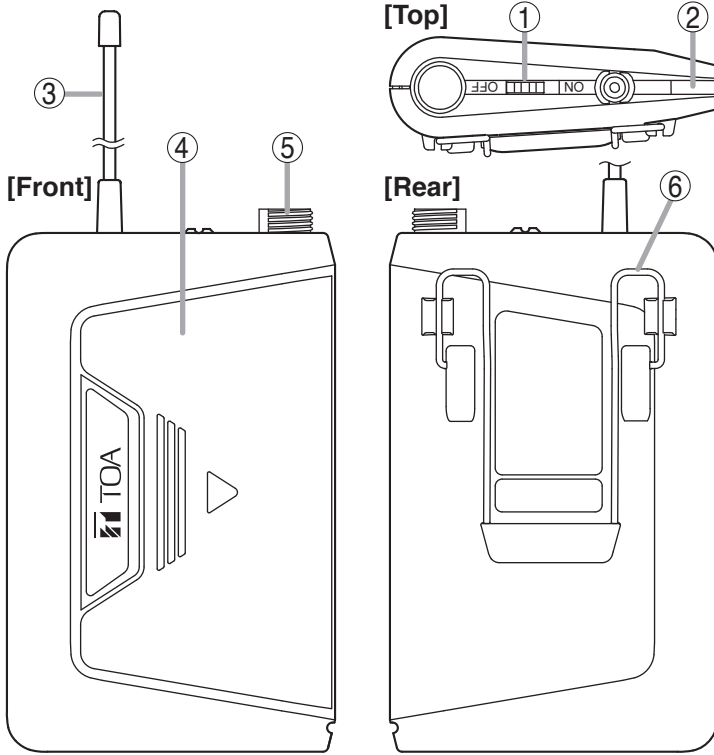

[Front (figure with the battery cover detached)]

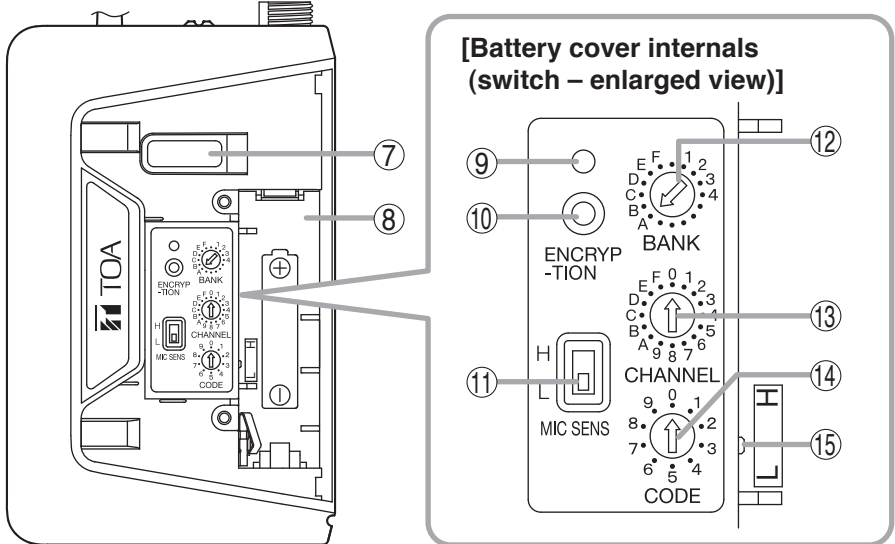

1. Power switch [ON/OFF]

Power can be turned on by sliding the power switch to the ON position, while it can be turned off by sliding it back to the OFF position.

2. Battery checker (green/orange/red)

Lit: Power ON
Unlit: Power OFF*

The remaining battery power is represented by the color of the indicator.

Green: Battery power is at full charge.

Orange: Battery power depletion has started.

Red: Battery power is almost depleted, and battery replacement is required.

* When the battery power is depleted, the indicator will not light up.

Note

The transmitter does not transmit the signal if the bank and channel selector switches are set to the empty channel.

In this case, the indicator flashes red and green alternately.

3. Antenna

A transmission-type antenna.

4. Battery cover

When inserting batteries or when setting the bank and channel, etc., the cover should be slid in the direction of the downward arrow (▽) mark.

5. Microphone input jack

Firmly insert the input plug of the microphone and lock it by turning the lock knob to the right.

6. Body clip

Convenient for when you want to attach the unit to your belt or chest pocket.

7. Maintenance port

Not used.

Note

Never open the rubber cover.

8. Battery compartment

Insert and use a dedicated rechargeable battery or AA alkaline batteries.

9. Encryption indicator

Lit: Encryption ON
Unlit: Encryption OFF

10. Encryption setting switch

11. Microphone sensitivity selector switch

[H/L]

H: +10 dB

L: 0 dB

12. Bank selector switch

Make sure that the transmitter is identical to the wireless receiver in the bank number.

13. Channel selector switch

Make sure that the transmitter is identical to the wireless receiver in the channel number.

14. Code setting switch [0 – 9]

15. Transmission output changeover switch

[H/L]

H: 10 mW

L: 1 mW

6. PREPARING BATTERIES

The WM-D5300 can operate on both the optional rechargeable battery or replaceable dry batteries. Please carefully read the corresponding sections for correct use.

6.1. Battery Insertion

Step 1. Turn off the power switch.

Step 2. Hold the transmitter body and slide the battery cover to the right to remove it.

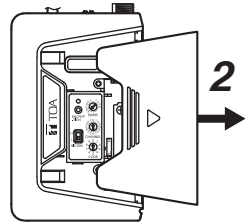

Step 3. Insert an AA battery according to (+) and (-) indications on the battery compartment.

For the rechargeable battery, use the optional TOA WB-2000-2 (package of 2).

For dry batteries, use either the supplied battery or commercial AA alkaline batteries (LR6).

Step 4. Replace the battery cover.

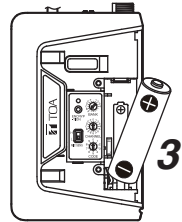

6.2. Guide to Battery Operating Times

6.2.1. Remaining operating time

The color of the battery checker changes from green to orange as battery consumption progresses, and to red if the battery is further continuously used. When the battery checker turns red, charge the battery if the dedicated rechargeable battery is used. In the case of dry batteries, replace it with a new one.

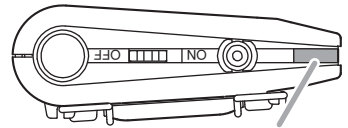

Green → Orange → Red

Guide to the remaining operating time based on the battery charge indicator status]

Battery checker status	Remaining operating time
Lights green	2 – 8 hours
Lights orange	Less than 2 hours
Lights red	Battery requires charge or replacement.

6.2.2. Continuous operating time

Guide to continuous operating times: Approx. 8 hours (for fully-charged dedicated rechargeable battery or alkaline battery)

Note

Operating times may vary depending on usage conditions, such as ambient temperature.

6.3. When Operating on Rechargeable Battery



CAUTION

Do not charge the unit with an alkaline dry battery installed.
Charge the dedicated rechargeable battery*.

Failure to observe these instructions could cause fire or personal injury due to a bursting battery.

* The optional TOA WB-2000-2 (package of 2).

Notes

- When operating on rechargeable batteries, the optional BC-2000 Battery charger is required.
- For rechargeable batteries, be sure to use the optional WB-2000-2 (package of 2).
- Avoid using other makes of rechargeable batteries.
- When using the WB-2000 rechargeable battery for the first time or when using it after it has been stored for a long period of time, be sure to charge it before use.
- The WB-2000 battery is designed to cycle through about 500 charges and discharges. When the transmitter operation interval becomes extremely short after prolonged repeated use, change the battery with a new one.
- Charge the rechargeable battery after it has been fully used. (The wireless transmitter will continue to operate for approx. 8 hours per charge.) Frequent charging at short intervals may shorten the operating life of the rechargeable battery.

[How to charge]

Step 1. Place the WB-2000 rechargeable battery in the wireless transmitter.
(See p. 7, "Battery Insertion.")

Step 2. Set the wireless transmitter's power switch to the OFF position.

Step 3. Fully insert the wireless transmitter into the microphone receptacle of the BC-2000 Battery charger.
The BC-2000's charging indicator lights red and charging begins.

- Charging is completed in approximately 3 hours and the BC-2000's full-charge indicator lights green.
- If the red charging indicator does not light even if the wireless transmitter has been inserted into the charger, check to see if the transmitter has been correctly inserted.
 - The wireless transmitter becomes warm after charging completion, however this is not a failure.
 - When disconnecting the wireless transmitter from the charger, firmly hold the charger so that it does not move.
- For more information, see the instruction manual enclosed with the BC-2000 Battery charger.

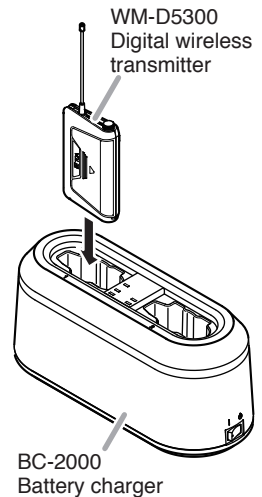

7. OPERATION

7.1. Preparing Microphone

The following optional microphones can be used. Purchase one of them separately.

Note

Be sure to switch OFF the transmitter's power switch before connecting or disconnecting the microphone element. A loud noise may be produced if this is done with the power switched ON.

[YP-M5300 Lavalier Microphone]

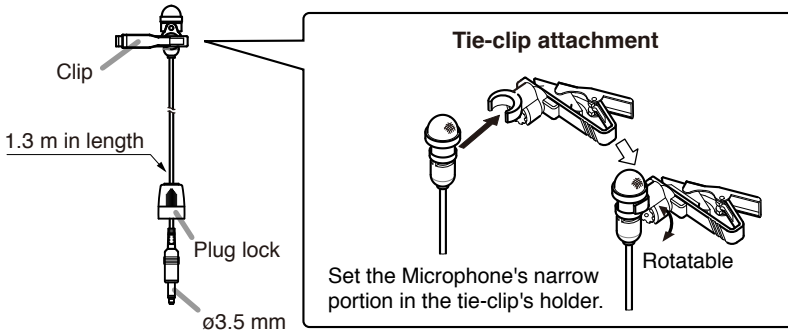

[YP-M5310 Lavalier Microphone]

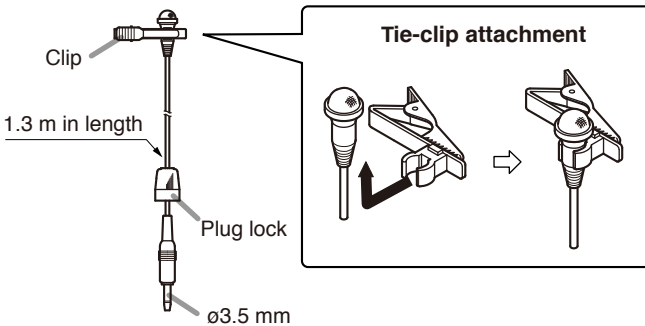

[WH-4000A Headset Microphone]

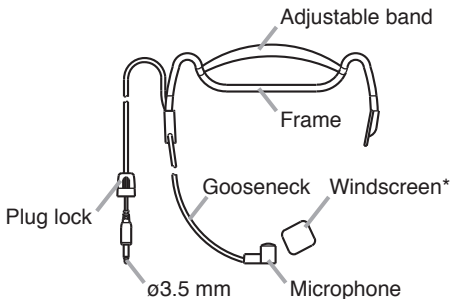

[WH-4000H Headset Microphone]

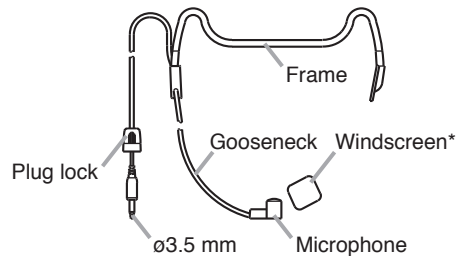

* Windscreens are also available as optional product WH-4000S.

7.2. Using Transmitter

- Step 1.** Plug the microphone's plug into the input connector as illustrated.
- Step 2.** Confirm that the wireless microphone and the wireless receiver are identical in the bank and channel number.
If not identical, turn the power switch to the OFF position, then set the bank and channel numbers to the same ones as the receiver.
- Step 3.** Turn the Power switch to the ON position.
Then, confirm the battery checker will light green or orange.
- Step 4.** Turn the Power switch to the OFF position after use.

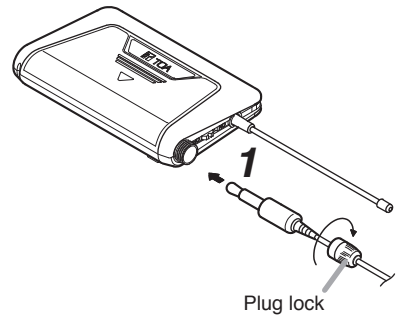

Secure the connection with the plug lock.

8. FUNCTION SETTINGS

8.1. Setting the Bank and Channel Numbers

- Step 1.** Turn off the power switch.
- Step 2.** Detach the battery cover.
- Step 3.** Using the supplied screwdriver, set the bank selector switch's pointer to the desired number, and set the channel selector switch's pointer likewise.
- Step 4.** Replace the battery cover.

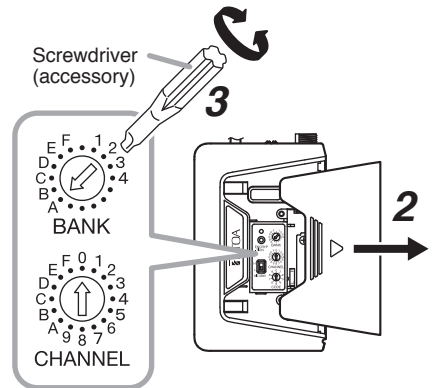

8.2. Performing Encryption Settings

To enhance security, the WM-D5300 is provided with an encryption setting function that prevents leakage of transmitted information.

This function also has the advantage of eliminating radio interference if enabled. Before enabling the encryption setting, be sure that bank and channel settings are completed first.

Note

In addition to the WM-D5300, the WT-D5800 Digital Wireless Receiver also requires setup. Therefore, be sure to see the receiver's instruction manual as well.

8.2.1. Encryption settings summary

[Before use (preparatory operation for setting)]

Transmit an ID number from the wireless transmitter to the receiver. The ID number is randomly selected on the wireless transmitter side. The ID number to be used is selected from an extensive number of combinations and cannot be designated by the operator, nor can it be identified from outside.

[In use] (No operations required.)

When the receiver detects a signal from the wireless transmitter, it simultaneously reads the transmitter's ID information, ensuring that only the audio of the wireless transmitter assigned with the same ID number as the receiver can be output. Even if the bank/channel numbers are identically set in an attempt to enable reception of a radio signal from outside, since no audio is output if the ID number does not match, the possibility of leakage of transmitted information to the outside is quite low.

[Encryption Setting ON/OFF Confirmation]

Step 1. After removing the battery cover, switch ON the transmitter power switch.

Step 2. Confirm the status of the Encryption indicator.

The setting is ON when the indicator is lit, and OFF when the indicator is unlit.

Note: The encryption setting is factory-preset to OFF.

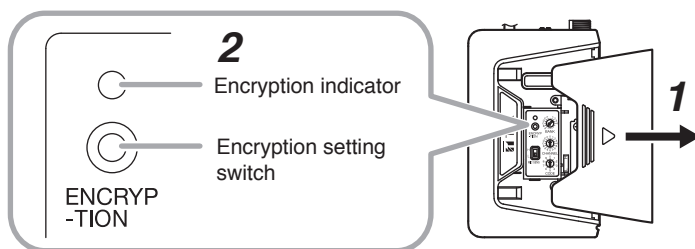

8.2.2. Performing encryption settings

[Switching the Encryption function from OFF to ON]

See also the instruction manual enclosed with the WT-D5800 receiver.

Step 1. Enable the receiver's encryption function.

Step 2. With the battery cover removed, switch ON the transmitter power switch and confirm that the Encryption indicator is unlit.
If the indicator is lit, switch encryption from ON to OFF (see p. 13).

Step 3. Switch OFF the transmitter power switch.

Step 4. Switch ON the transmitter power switch while holding down the transmitter's Encryption setting switch (continue holding until **Step 6**). Confirm that the transmitter's Encryption indicator is flashing.
An ID number is transmitted while the transmitter's Encryption setting switch is held down.

Step 5. Perform pairing setting at the receiver.
The receiver waits for the transmitter's transmitted ID number for as long as the Set key is held down. The "RECEIVING" indication is displayed on the receiver's LCD screen until the ID number is correctly received.

Step 6. After confirming that the LCD display has switched to the "SUCCESS" indication, release both the transmitter's Encryption setting switch and the receiver's Set key.

Step 7. Confirm that the transmitter's Encryption indicator is lit.
The encryption setting is now ON.

Notes

- Do not switch OFF the power to the transmitter or receiver during setting.
- Hold down the transmitter's Encryption setting switch and the receiver's Set key until the "SUCCESS" indication appears on the receiver's LCD screen. If the transmitter's Encryption setting switch or the receiver's Set key is released while the "RECEIVING" indication is displayed on the receiver's screen, the receiver will not have correctly received the new ID number, leaving the ID number unchanged from the previous value. To match the receiver ID number with the transmitter ID number, switch OFF the transmitter's encryption setting, then repeat **Steps 1 – 7** above.

Tips

- The ID number is updated when the encryption is switched from OFF to ON again. (The encryption ON/OFF status and ID number are retained even if the power switch is switched OFF.)
- Settings can be performed regardless of whether the transmitter or receiver Encryption setting switch was depressed first.
- The receiver does not output audio during ID number setting, even if it receives a radio signal from the transmitter.

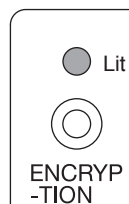
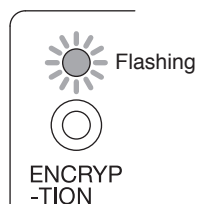
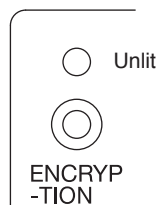

[Switching the Encryption function from ON to OFF]

Step 1. With the battery cover removed, switch ON the transmitter power switch and confirm that the Encryption indicator is lit.

Step 2. Switch OFF the power switch.

Step 3. Switch ON the transmitter power switch while holding down the Encryption setting switch.

Note

Do not switch OFF the transmitter power switch during setting.

Step 4. Confirm that the Encryption indicator has extinguished, then release the Encryption setting switch.
The encryption setting switches to OFF.

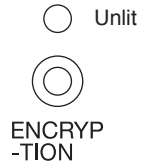
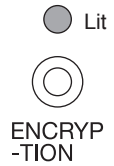

8.3. Performing Code Settings (When Encryption Function Is OFF)

8.3.1. Code setting summary

By presetting the specified code between the wireless transmitter and receiver, audio is only output when a digital signal received from the wireless transmitter has the same ID code as the receiver. Even if another signal is received from an adjacent area, if the code does not match, audio is not output.

Ten varieties of code can be selected ([0] – [9]) for appropriate use, depending on circumstances.

8.3.2. Code settings

Code is factory-preset to "0."

Note

Switch OFF the transmitter power switch when performing settings. If the power switch is left ON, the codes will remain unaffected even if the settings are manually changed.

Step 1. After removing the battery cover, switch ON the transmitter power switch.

Step 2. Confirm that the Encryption indicator is unlit.
If it is lit, switch encryption from ON to OFF, referring to p. 12, "Switching the Encryption function from OFF to ON."

Step 3. Switch OFF the power.

Step 4. Using the supplied screwdriver, set the code setting switch to the desired code number.

Step 5. Replace the battery cover, as it was before.
This puts the code into the set state.

Step 6. Set the same code number for the receiver, as well.
For the setting method, see the instruction manual enclosed with the receiver.

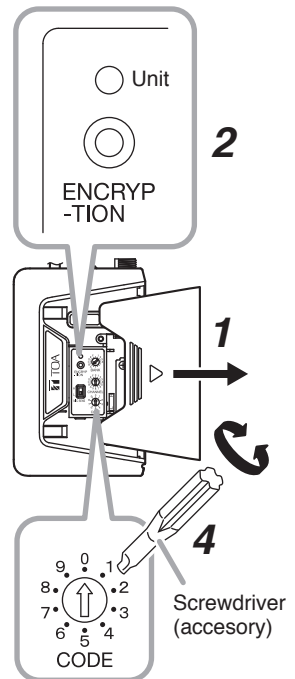

8.4. Performing Transmission Output Changeover Switch Settings

Transmission can be set for either of two outputs: 'H' (10 mW) or 'L' (1 mW). The switch is factory-preset to the 'H' position.

Note

Be sure to turn the transmitter's power switch OFF before performing settings.

Step 1. Confirm that the power switch is turned OFF, then remove the battery cover.

Step 2. Using the supplied screwdriver, set the changeover switch to the desired transmission output.

Set the switch to the 'H' position when using the transmitter in a wide area.

If the same bank and channel are used in close proximity in adjacent locations, set the switch to the 'L' position to shorten the radio wave transmission range for each location to minimize interference.

Step 3. Securely replace the battery cover.

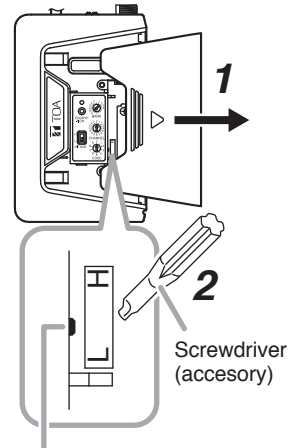

9. CONVENIENT FUNCTIONS (Microphone Sensitivity Selector Switch Settings)

Microphone sensitivity can be set to "0 dB" (H) or "-10 dB" (L).

Notes

- Switch OFF the power switch when selecting the sensitivity.
- Avoid positioning the microphone too close to the mouth or speaking in a loud voice, as the sound could become muddled and difficult to understand.
- Sensitivity is factory-preset to "L."

Step 1. Confirm that the power switch has been switched off, then remove the battery cover.

Step 2. Using the supplied screwdriver, set the switch to the desired sensitivity.

Step 3. Replace the battery cover, as it was before.

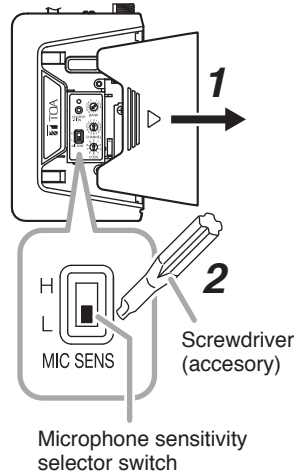

10. SPECIFICATIONS

Version	WM-D5300 -C4, WM-D5300 -C7	WM-D5300 -G1
Frequency Range	794 – 832 MHz (794 – 806 MHz for Thailand)	606 – 636 MHz
Modulation type	FSK	
Channel Selectable	160 channels (The number of channels may differ from country to country.)	
RF Carrier Power	Less than 50 mW	
Maximum Input Level	–18 dB* (Sensitivity: L)/–28 dB* (Sensitivity: H)	
Audio Frequency Response	100 Hz – 12 kHz	
Antenna	Lamda/4 whip antenna	
ID Selectable	10 patterns	
Battery	WB-2000 rechargeable battery (option) or AA Alkaline dry cell battery	
Battery Life	Approx. 8 hours	
Operating Temperature	–10 to +50 °C (14 to 122 °F) (except battery)	
Operating Humidity	30 to 85 %RH (no condensation)	
Finish	Body: ABS resin, black, paint	
Dimensions	62 (w) × 171 (h) × 19 (d) mm (2.44" × 6.73" × 0.75")	62 (w) × 185 (h) × 19 (d) mm (2.44" × 7.28" × 0.75")
Weight	90 g (0.2 lb) (with battery)	

* 0 dB = 1V

Note: The design and specifications are subject to change without notice for improvement.

• Accessories

Storage case 1
Screw driver (for setting) 1

• Optional products

Unidirectional lavalier microphone: YP-M5300
Omnidirectional lavalier microphone: YP-M5310
Headset microphone: WH-4000A, WH-4000H

Note

The WM-D5300 cannot communicate with the TRANTEC Wireless System (S4 and S5 Series) nor with the TOA Analog Wireless System (WT-5800, WT-5805, and WT-5810 etc.).



DECLARATION OF CONFORMITY

We: TOA Electronics Europe GmbH
Süderstraße 282, 20537 Hamburg, Germany

as the authorised representative of the

Manufacturer: TOA Corporation
7-2-1, Minatojima-nakamachi, Chuo-ku, Kobe, Japan 650-0046

declare, under our sole responsibility, that the product

Product Name: **DIGITAL WIRELESS TRANSMITTER**

Model Number: **WM-D5300**

conforms with following specifications:

EMC: ETSI EN 301 489-1: V1.9.2 (2011-09),
ETSI EN 301 489-9: V1.4.1 (2007-11)

ERM: ETSI EN 300 422-2: V1.4.1 (2015-06)

LVD : EN 60950-1: 2006 + A11: 2009 + A1: 2010 + A12: 2011 + A2: 2013

RoHS: EN 50581: 2012

Health: EN 62479: 2010

The product herewith complies with the requirements of the EU directives:
2011/65/EU relating to the restrictions of hazardous substances (RoHS),
1999/5/EC relating to the spectrum (ERM, EMC, LVD, Health).



Hamburg, 29th November 2016
(place, date)

T. Sakata, Managing Director
(authorised signature)

The Technical Construction File (TCF) is kept at the UK office:

TOA Corporation (UK) Ltd; Unit 7 & 8, The Axis Centre, Cleeve Road, Leatherhead, Surrey, KT22
7RD, United Kingdom

Tel.: +44 (0) 870 774 0987; Fax: +44 (0) 870 777 0839; URL: www.toa.co.uk

German Office:

TOA Electronics Europe GmbH, Süderstraße 282, 20537 Hamburg, Germany
Tel: +49 / (0)40 / 25 17 19-0, Fax: +49 / (0)40 / 25 17 19-98 URL: www.toa.eu

COMPLIANCE STATEMENT TO WM-D5300

AT DE	Österreich Deutschland	Hiermit erklärt TOA Electronics Europe GmbH die Übereinstimmung des Funkmikrofon mit den grundlegenden Anforderungen und den anderen relevanten Festlegungen der Richtlinie 1999/5/EG.
BE	België	Bij deze verklaart TOA Electronics Europe GmbH dat deze draadloze microfoon voldoet aan de essentiële eisen en aan de overige relevante bepalingen van Richtlijn 1999/5/EC.
	Belgique	Par la présente, TOA Electronics Europe GmbH déclare que ce microphone sans fil est conforme aux exigences essentielles et aux autres dispositions de la directive 1999/5/CE qui lui sont applicables.
CH	Schweiz	Hiermit erklärt TOA Electronics Europe GmbH, dass sich dieses Funkmikrofon in Übereinstimmung mit den grundlegenden Anforderungen und den anderen relevanten Vorschriften der Richtlinie 1999/5/EG befindet. (verantwortlich für die Schweiz: Telion AG, URL: www.telion.ch)
DK	Danmark	Undertegnede TOA Electronics Europe GmbH erklærer herved, at følgende udstyr Trådløs Mikrofon overholder de væsentlige krav og øvrige relevante krav i direktiv 1999/5/EF.
ES	España	TOA Electronics Europe GmbH declara que el micrófono inalámbrico cumple con los requisitos esenciales y otras disposiciones aplicables o exigibles en la Directiva 1999/5/CE.
FI	Suomi / Finland	TOA Electronics Europe GmbH vakuuttaa täten tämä langaton mikrofoni on direktiivin 1999/5/EY oleellisten vaatimusten ja sitä koskevien direktiivin muiden ehtojen mukainen.
FR CH	France Suisse	Par la présente TOA Electronics Europe GmbH déclare que l'appareil microphone sans fil est conforme aux exigences essentielles et aux autres dispositions pertinentes de la directive 1999/5/CE. (CH : Telion AG, URL : www.telion.ch)
GB	Great Britain	Hereby, TOA Electronics Europe GmbH, declares that this wireless microphone is in compliance with the essential requirements and other relevant provisions of Directive 1999/5/EC.
GR	Ελλάδα	Με την παρούσα η εταιρεία TOA Electronics Europe GmbH δηλώνει ότι το ασύρματο μικρόφωνο συμμορφώνεται με τις ουσιαστικές απαιτήσεις και τις λοιπές σχετικές διατάξεις της οδηγίας 1995/5/EK.
IT CH	Italia Svizzera	Con la presente TOA Electronics Europe GmbH dichiara che questo Radiomicrofono è conforme ai requisiti essenziali ed alle altre disposizioni pertinenti stabilite dalla direttiva 1999/5/CE. (CH: Telion AG, URL: www.telion.ch)
NL	Nederland	Hierbij verklaart TOA Electronics Europe GmbH dat deze draadloze microfoon in overeenstemming is met de essentiële eisen en de andre relevante bepalingen van richtlijn 1999/5/EG.
NO	Norway	TOA Electronics Europe GmbH erklærer herved, at denne trådløse mikrofoni er i samsvar med de vesentlige egenskapene og øvrige relevante krav i direktiv 1999/5/EC. (N: Scandec Systemer AS, URL: www.scandecsystemer.no)

PT	Portugal	TOA Electronics Europe GmbH declara que este Microfone Emissor está conforme com os requisitos essenciais e outras disposições da Directiva 1999/5/CE.
SE	Sverige	Härmed intygar TOA Electronics Europe GmbH att denna Trådlös mikrofon står i överensstämmelse med de väsentliga egenskapskrav och övriga relevanta bestämmelser som framgår av direktiv 1999/5/EG.

INTENDED USE OF WM-D5300

AT CH DE	Österreich Schweiz Deutschland	WICHTIGER HINWEIS !	<p>Der Gebrauch dieses Funkmikrofons für andere Zwecke als zur Übertragung eines Tonsignals an einen passenden Funkempfänger ist nicht zulässig.</p> <p>Dieses Gerät arbeitet auf in der europäischen Gemeinschaft (EU) nicht harmonisierten Frequenzen. Abhängig vom geografischen Gebiet dürfen nur bestimmte Frequenzen legal mit oder ohne Autorisierung/individueller Lizenz entsprechend der beigefügten Frequenztafel genutzt werden.</p>
BE NL	België Nederland	BELANGRIJKE AANWIJZING !	<p>Het is niet toegestaan deze draadloze microfoon te gebruiken voor enig ander doel dan het zenden van een audiosignaal naar de bijbehorende ontvanger of ontvangstmodule.</p> <p>Dit apparaat maakt gebruik van frekwentiebanden welke in de Europese Gemeenschap (EG) niet algemeen zijn toegestaan. Afhankelijk van de geografische ligging kan voor het legaal gebruik van een bepaalde frekwentie een vergunning nodig zijn, zoals is aangegeven in de frekwentietabel.</p>
BE CH FR LU	Belgique Suisse France Luxembourg	AVIS IMPORTANT !	<p>Ne pas utiliser les microphone sans fil pour une transmission du signal audio vers un autre récepteur ou module tuner prévu à cet effet.</p> <p>Cet appareil utilise des fréquences d'émission qui ne sont pas harmonisées à travers la Communauté Européenne (EU). En fonction du lieu géographique certaines fréquences peuvent être utilisée de façon légale avec ou sans autorisation / licence individuelle comme décrit dans le tableau des fréquences.</p>
DK	Danmark	VIGTIGT !	<p>Det er ulovligt at bruge denne trådløse mikrofon til andre formål end at sende et lydssignal til en passende modtager eller modtager modul.</p> <p>Dette udstyr anvender frekvens bånd, som ikke er harmoniseret i EU. Afhængigt af det enkelte land/område kan bestemte frekvenser anvendes lovligt med eller uden individuel licens som beskrevet i frekvens tabellen.</p>

ES	España	¡ AVISO IMPORTANTE !	<p>Es ilegal utilizar este micrófono inalámbrico para cualquier otro propósito que no sea transmitir una señal de audio a su correspondiente receptor o módulo sintonizador.</p> <p>Este dispositivo hace uso de bandas de frecuencia que no son legales en toda la Comunidad Europea (CE). Dependiendo del área geográfica, ciertas frecuencias se pueden utilizar legalmente, con o sin autorización individual, según se indica en la tabla de frecuencias.</p>
FI	Suomi / Finland	HUOMIOITAVAA !	<p>Tätä langatonta mikrofonia saa käyttää ainostaan audiosignaalien lähettämiseen sille tarkoitettuun vastaanottimeen tai vastaanotinmoduliin.</p> <p>Tämä laite käyttää taajuuksia jotka eivät ole yhteneviä koko EU:n alueella. Riippuen maantieteelliestä sijainnista joitain taajuuksia saa käyttää joko radio- luvan kanssa tai ilman. Ks. oheinen taajuustaulukko.</p>
GB IE	Greate Britain Eire	IMPORTANT NOTICE !	<p>It is illegal to use this wireless microphone for any other purpose than transmitting an audio signal to its matching receiver.</p> <p>This device makes use of frequency bands which are not harmonised throughout the European Community (EU). Depending on the geographical area only certain frequencies can be used legally with or without authorisation / individual license as stated in the frequency table.</p>
GR	Ελλαδα	ΣΗΜΑΝΤΙΚΗ ΣΗΜΕΙΩΣΗ !	<p>Είναι παράνομη η χρήση του ασύρματου μικροφώνου για οποιοδήποτε άλλο λόγο εκτός της εκπομπής ηχητικού σήματος στον αντίστοιχο δέκτη ή μονάδα Tuner.</p> <p>Η συσκευή αυτή χρησιμοποιεί συχνότητες οι οποίες δεν εναρμονίζονται σε όλη την Ευρωπαϊκή Ένωση (Ε.Ε.). Ανάλογα με τη γεωγραφική περιοχή συγκεκριμένες συχνότητες μπορούν να χρησιμοποιηθούν νόμιμα με ή χωρίς άδεια / ειδική άδεια όπως αναφέρεται στον πίνακα συχνοτήτων.</p>

IT CH	Italia Svizzera	AVVISO IMPORTANTE !	<p>È illegale utilizzare questo radiomicrofono per qualsiasi altro scopo che non sia la trasmissione di un segnale audio ad ogni suo ricevitore o modulo sintonizzatore.</p> <p>Questo prodotto utilizza bande di frequenza che non sono totalmente armonizzate in tutta la Comunità Europea (EU). Dipendentemente dall'area certe aree geografica certe frequenze possono essere usate legalmente con o senza autorizzazione / licenze individuali come stabilito nella tabella delle frequenze.</p>
NO	Norway	VIKTIG MELDING !	<p>Det er ulovlig å bruke denne trådløse mikrofonen til noe annet formål enn å overføre et lydsignal til en tilhørende mottaker eller tuner modul.</p> <p>Denne enheten gjør bruk av frekvensbånd som ikke gjennomført er harmonisert i det Europeiske Fellesskap (EU). Avhengig av det geografiske område kan noen frekvenser være tillatt brukt med eller uten autorisasjon / individuelle lisenser slik det er beskrevet i frekvenstabellen.</p>
PT	Portugal	NOTA IMPORTANTE !	<p>Este Microfone Emissor só pode transmitir sinal de audio para o respectivo receptor ou sintonizador.</p> <p>Este equipamento utiliza bandas de frequência que não estão harmonizadas em toda a Comunidade Europeia (CEE). De acordo com a área geográfica, certas frequências podem ser usadas com ou sem autorização / licença individual, conforme está mencionada na lista de frequências.</p>
SE	Sverige	VIKTIG ANMÄRKNING !	<p>Det är illegalt att använda denna trådlösa mikrofon för något annat ändamål än att överföra en audiosignal till dess tillhörande mottagare eller tunermodul.</p> <p>Denna apparat utnyttjar frekvensband som inte överensstämmer med varandra inom hela Europeiska Gemenskapen (EG). Beroende på geografiskt område kan vissa frekvenser användas legalt med eller utan tillstånd/ individuell licens enligt frekvensplanen.</p>

Traceability Information for Europe

Manufacturer:

TOA Corporation
7-2-1, Minatojima-Nakamachi, Chuo-ku, Kobe, Hyogo,
Japan

Authorized representative:

TOA Electronics Europe GmbH
Suederstrasse 282, 20537 Hamburg,
Germany