

DESCRIPTION

The RS-144 is a switch panel designed for use with the N-8000RS or N-8010RS 2-Core Shielded Substation Interface Unit. It is equipped with a Emergency button and Normal button, and can be installed in a 1-gang electrical box.  
 By connecting a high impedance speaker to it, hands-free conversation with the master station can be made through its speaker.  
 Also, it can be used in connection with the RS-141 Ip Intercom Option Handset.

SPECIFICATIONS

Call Button	Momentary (EMERGENCY, NORMAL)
Wiring	Two-core shielded cable
Transmission Range	0.5 km (546 yd)/ø0.5 mm (AWG24) 0.8 km (874 yd)/ø0.65 mm (AWG22) 1.3 km (1421 yd)/ø0.9 mm (AWG19)
Operating Temperature	0 °C to +40 °C (32 °F to 104 °F)
Finish	Plate: Stainless steel, hairline Call Button (emergency): resin, red Call Button (normal) : resin, white
Dimensions	70 (W) × 115 (H) × 28.6 (D) mm (2.76" × 4.53" × 1.13")
Weight	80 g (0.18 lb)
Accessory	Mounting bracket .....1, bracket mounting screw (No.6-32UNC × 18) .....2, Box mounting screw (M4 × 30) .....2, Box mounting screw (No.6-32UNC × 30) .....2
Applicable Box	Flush-mount box: YC-801 (option) Wall-mount box : YC-802 (option)

APPEARANCE

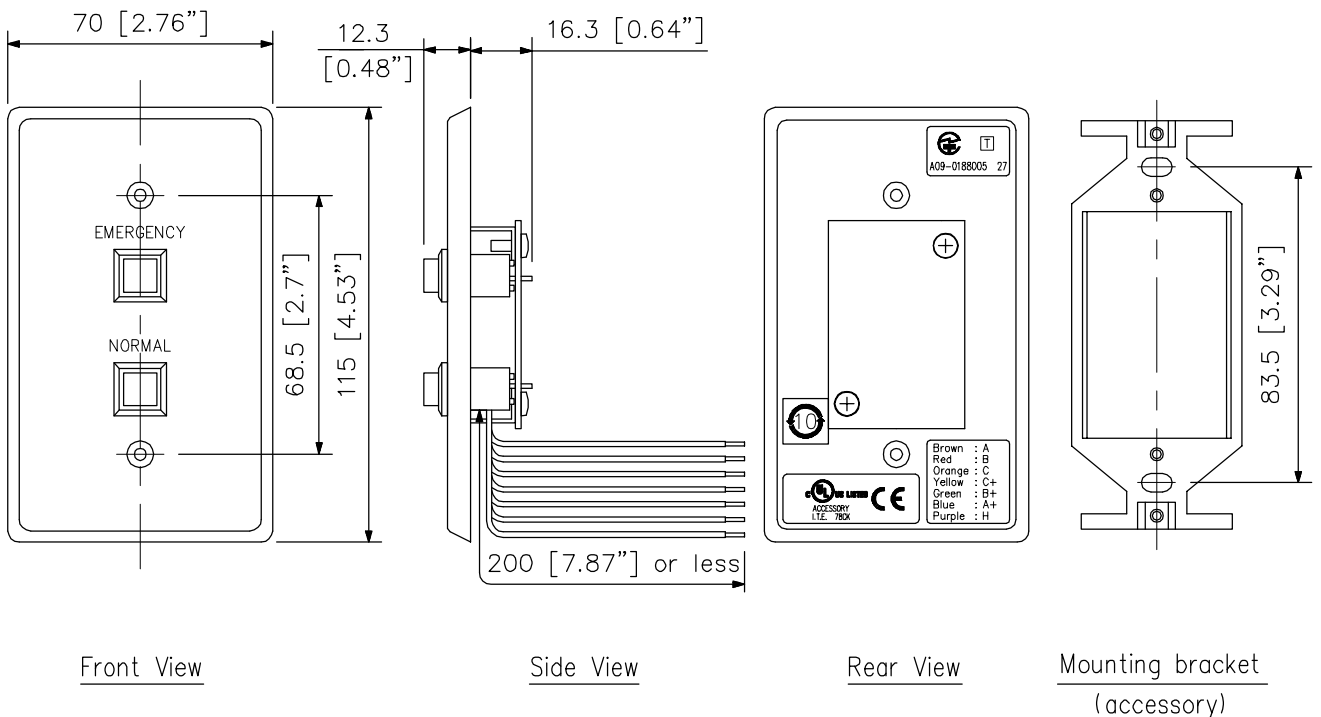

UNIT:mm SCALE:1/2